



Autofocus 1D and 2D Code Reader
SR-1000 Series



SETTING THE NEW STANDARD FOR CODE READING

SR-1000 Series



SR-1000 Series

3 CHALLENGES

CODE READERS FACE

1

READER CANNOT BE MOUNTED AT DESIRED DISTANCE

“Selecting the right reader and lens combination for the distance is frustrating.”
“The system has to be designed to fit the specifications of the reader.”



2

OPTIMAL SETTINGS ARE UNKNOWN

“Reading was successful during setup but there are many errors during actual operation.”
“Setup requires a whole day.”



3

READING FAILS DUE TO GLARE

“Do we need to mount the reader at a certain angle? What is the best angle?”
“Is external lighting required? What kind?”



1 ANSWER JUST PRESS THE BUTTON



PRESS THE BUTTON

AUTOFOCUS

1

The reader can be mounted at any distance and maintain a clear image. (1000 mm max.)

AUTOMATIC TUNING

2

Determines optimal settings for exposure time, image processing filter, etc. [About 750000 combinations]

AUTOMATIC POLARIZATION

3

Glare can be eliminated. Reader angle adjustment or external lighting is unnecessary.



SETTING COMPLETE

Autofocus 1D and 2D code reader
SR-1000 Series

WORLD'S FIRST AUTOMATIC POLARIZATION CONTROL

The reader features both polarized and direct light sources. Automatic polarizing filter selection eliminates glare and allows flexible mounting.

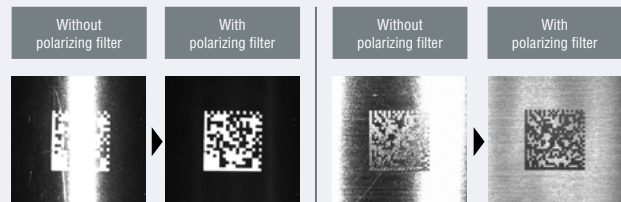

1 JUST PRESS THE BUTTON

AUTOFOCUS

ONE READER FOR MANY APPLICATIONS

Mounting is less restricted by performance or specifications of the code reader itself, thus improving flexibility in machine designs for production lines and jigs. With autofocus capabilities, a single reader can detect codes on targets of varying heights.

- Detecting targets with differing heights
- Securing a robot's movement range
- Reading extremely small codes

FIELD OF VIEW 4x LARGER

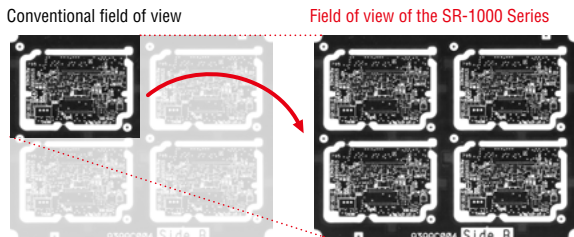

EVEN IF THE CODE IS
SMALL

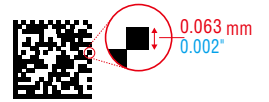

Distance:
110 mm
4.33"

Range:
290 mm × 220 mm
11.42" × 8.66"

4x WIDER
than conventional models

EVEN IF THE POSITION
CHANGES

Distance:
1000 mm
39.37"

1.6x LONGER
than conventional models

EVEN IF THE DISTANCE IS
FAR















AUTOMATIC TUNING

OPTIMAL SETTING OF EXPOSURE TIME, FILTERS AND MORE

The code reader automatically optimizes the exposure time, image processing filter and other parameters according to the target and mounting distance.

CLEAR IMAGE CAPTURE

CORRECTION ITEMS AND EXAMPLES OF AFFECTED CODES

 Dark	CAPTURE BRIGHTNESS CORRECTION Automatically configures various combinations of exposure time, dynamic range and gain in order to achieve the optimal brightness.	 Black resin	 PCB
 Low contrast	CONTRAST THRESHOLD CORRECTION Automatically corrects black/white thresholds and optimizes the contrast between code and background.	 Metal	 Ceramic
 Thin printing	FILTER CORRECTION Automatically selects the best filter and filtering intensity to correct the captured image.	 Bleeding	 Thick printing
 Distortion	GEOMETRIC CORRECTION Corrects distorted codes, such as those on cylinders and other round surfaces or when the reader is mounted at an angle.	 Parallel distortion	 Trapezoidal distortion
 Stray dots	IMAGE REDUCTION & CORRECTION Reducing the image size may reduce background noise or missing spaces relatively smaller.	 Primary noise	 Dot printing

APPLICATIONS

Automotive and metal works industries

CRANKSHAFTS

INSPECTIONS

The large field of view and autofocus function compensate for changes in both the position and reading distance of codes between product types.

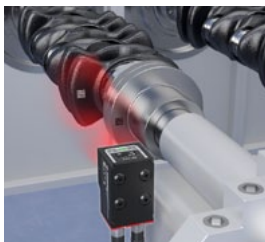

Electronic devices industry

LEAD FRAMES

BONDING

This single device can read both extremely small codes and codes discolored by heat or oxidation.



Food, medical, and packaging industries

FOOD PACKAGING

VARIETY INSPECTIONS

Reads codes over a large field of view and at high speeds, even as position and orientation of codes vary.



CAMSHAFTS

PROCESSING

Automatically eliminates glare caused by cylindrical and metallic materials to stabilize reading.



IC CHIPS

INSPECTIONS

Simultaneously reads multiple codes in a tray of ICs for identification.

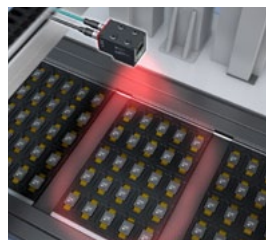

MEDICINAL PACKAGING

PACKAGING

Reliably captures barcodes and 2D codes traveling at high speeds to help contribute to ever-increasing safety checks.



AUTOMATIC POLARIZATION CONTROL

ENSURING FLEXIBLE MOUNTING

Automatic polarization control function World's First

The code reader automatically eliminates glare, thus eliminating the need for mounting angle adjustment or external lighting during installation. When combined with the autofocus function, mounting becomes highly flexible.

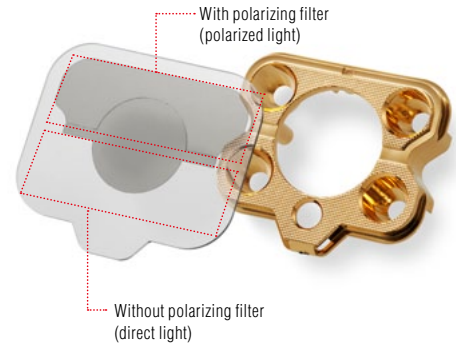

BLACK RESIN	
CYLINDER	
METAL	
HAIRLINE	
METAL	
DPM ON CAST SURFACE	

Without polarizing filter	With polarizing filter
ERR 	OK
ERR 	OK
OK 	ERR

NEW OPTICAL DESIGN FOR STABLE READING

CPC (Compound Parabolic Concentrator) Illumination

A specially shaped reflector has been designed to create high efficiency illumination by reducing loss in light intensity from the high intensity LEDs. Gold plating maximizes the reflectance to achieve brightness exceeding conventional levels by 400%. This provides reading under bright, uniform illumination even at long ranges.

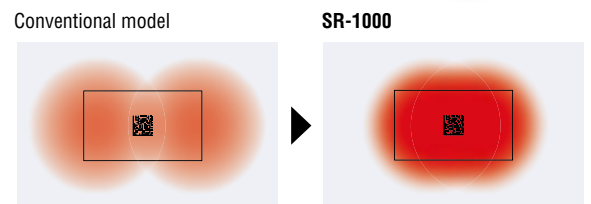

Light is concentrated efficiently within the field of view to provide high intensity illumination.

TWO MODES CAN BE SELECTED DEPENDING ON THE APPLICATION



UNAFFECTED BY CHANGING CONDITIONS

SMART MODE NEW

FOR CONSISTENT READING REGARDLESS OF CODE CONDITIONS



LIGHTER CODE

Fluctuations in code conditions are predicted during tuning and expanded reading settings are automatically generated. This ensures stable reading even when the contrast of the code changes, eliminating the need to reconfigure the code reader.

The reader predicts 43 patterns of change in printing conditions.

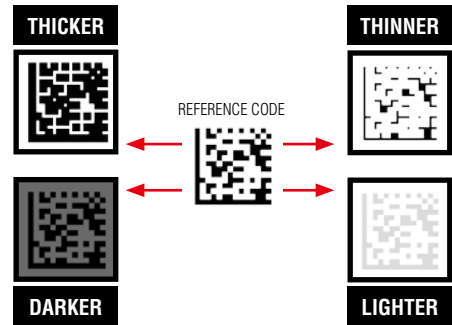

DETECTING CHANGES IN CODE CONDITIONS

CUSTOM MODE

FOR CODE QUALITY MANAGEMENT

The SR-1000 has the functionality to make judgments on code quality. Because code quality degradation can be detected before reading errors occur, this mode can be used for predictive maintenance of the printing process.

Matching level judgment function

Provides code quality comparison

Two codes, which both have a reading rate of 100%, can still be distinguished by the matching level



Reading rate **100%**
Matching level **75**



Reading rate **100%**
Matching level **43**

Code verification function

Verification based on code quality standards

OUTPUT DATA **AD-ERMT-55841:B**

TOTAL GRADE JUDGMENT

Judgment can also be given for each parameter

*This function is designed for 2D codes (QR, DataMatrix, GS1 Composite, PDF417).



SUPPORTED STANDARDS

- ISO/IEC 15415
- ISO/IEC TR 29158 (AIM DPM-1-2006)
- ISO/IEC 16022
- SAE AS9132
- SEMI T10-0701

EASY-TO-USE HIGH PERFORMANCE

ADVANCED SETUP SOFTWARE

SR-H6W NEW



The software provides not only easy code reader setup but also functionality to reduce man-hours for preliminary tests. It is possible to connect to the software through USB.

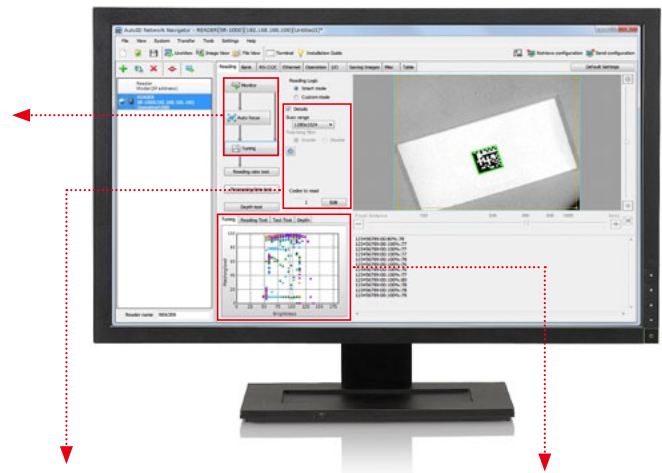
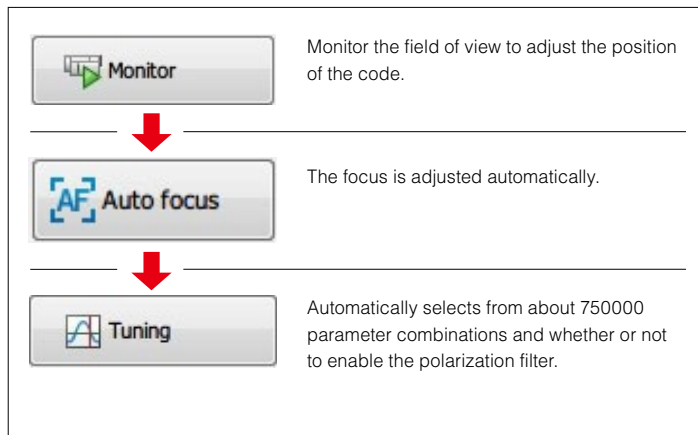

ADVANCED SETTINGS

Details

Image capture range
1280x1024

Polarizing filter
 Enable Disable

Bank to Tune/Test
1

Test with target bank
Codes to read
1

IMAGE CAPTURE RANGE

The smaller the range, the shorter the reading time becomes. Selectable from 800 × 600 mm 31.50° × 23.62°, 1280 × 1024 mm 50.39° × 40.31°, and user defined.

TARGET BANK (in custom mode only)

Specify the parameter bank number to modify.

TUNING HISTORY (in custom mode only)

Tuning history can be reviewed.

POLARIZATION FILTER

Selectable between enabled or disabled.

NO. OF CODES FOR READING

Specify the number of codes to read simultaneously.

TUNING MONITOR

The optimum settings are automatically determined from multiple combinations of image processing filters and brightness levels.

ETHERNET COMMUNICATION WIZARD NEW

Setup can be completed in just four steps with a question-answer form including visual explanations. In previous versions, the user needed to understand the settings available on the screen and determine which items required input. The new version uses a setup wizard to eliminate the need for item extraction, reducing man-hours for communication setup.

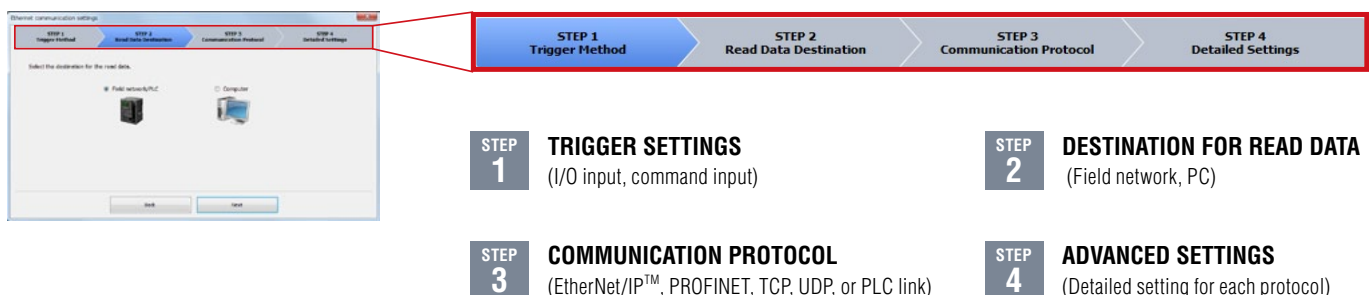

SOPHISTICATED MEASUREMENT MODES

The SR-1000 Series provides pre-verification prior to line operation based on tuning results as well as measurement of allowable line speed for reading codes at high speeds.

READING RATE MEASUREMENT

The reading success rate can be measured without conducting reading tests on multiple targets with the actual production line or equipment.

Tuning	Reading Test	Tact Test	Depth
Reading Test	100%		
Matching level	97		
Symbology	DataMatrix(12 x 12)		
Cell size	1.00mm		
Code size (width)	12.0mm		
PPC	25.0pixel/cell		
Read Data	123456789		

READING TACT MEASUREMENT

The reading cycle time (tact) can be determined without conducting reading tests on multiple targets with the actual production line or equipment.

Tuning	Reading Test	Tact Test	Depth
Read time	32ms		
Max time	33ms		
Min time	32ms		
Read Data	123456789		

READING DEPTH MEASUREMENT NEW

The depth of field can be determined from the mounting distance and the code used for tuning, without conducting reading tests on targets with the actual production line or equipment.
(When the mounting distance changes, perform re-tuning to enable reading again.)

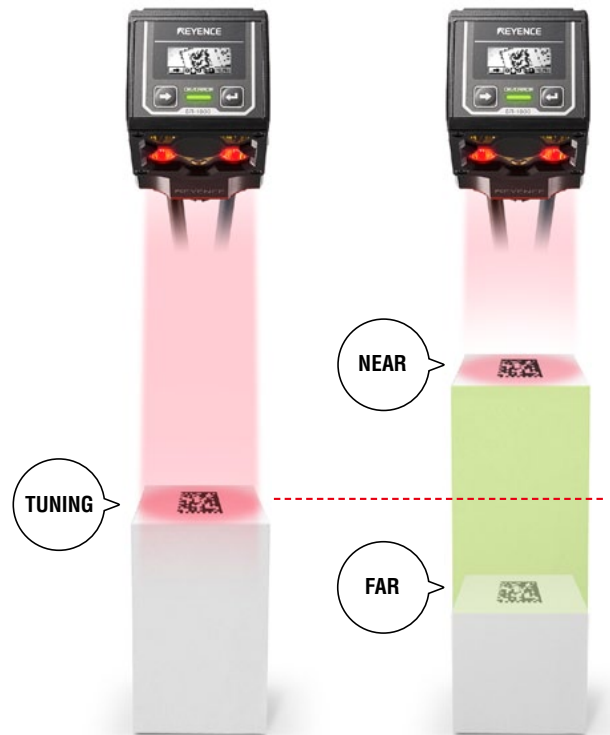
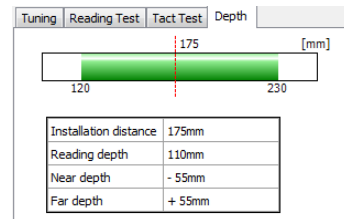

LINE SPEED MEASUREMENT NEW

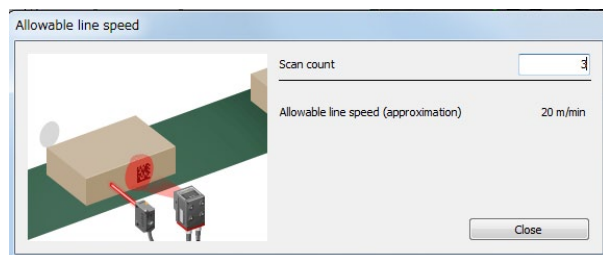

You can check allowable line speed before installation. This helps reduce man-hours spent adjusting production line designs or jigs.

FIRST-IN-ITS-CLASS, BUILT-IN ORGANIC LED (OLED) DISPLAY

CHECK OPERATION ON-SITE WITHOUT A PC

There is no need for a personal computer or monitor in the facility. The code position adjustment and operating condition can be checked simply with the intuitive built-in display.

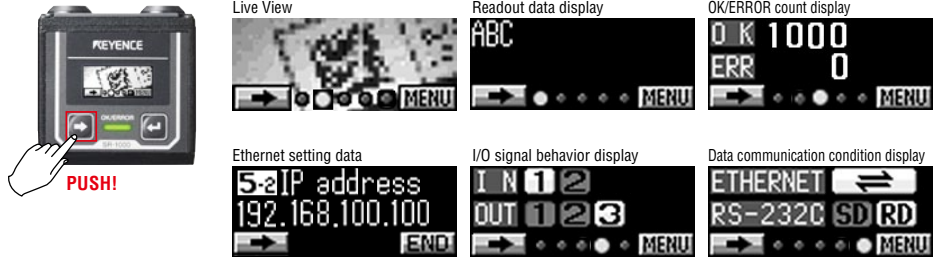

EASY SETUP WITHOUT A PC

You can set the optimal reading parameters after adjusting the code position by simply pressing the ENTER button to complete fully automatic tuning.

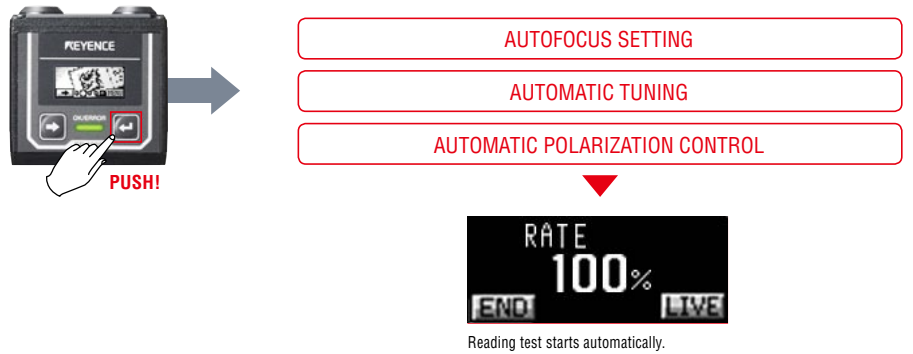

HIGHLY-ADVANCED FUNCTIONS OFFER SIMPLE OPERATION

MASTER/SLAVE FUNCTION FOR USING MULTIPLE READERS EFFICIENTLY

The master reader can control up to 31 slave readers when multiple readers are used. (Up to 7 slave readers can be controlled in multi-head mode.) This function drastically reduces the programming load on the host computer/PLC.

* SR-D100/750 Series units can also be added (in combination with SR-1000 Series units) into this function.

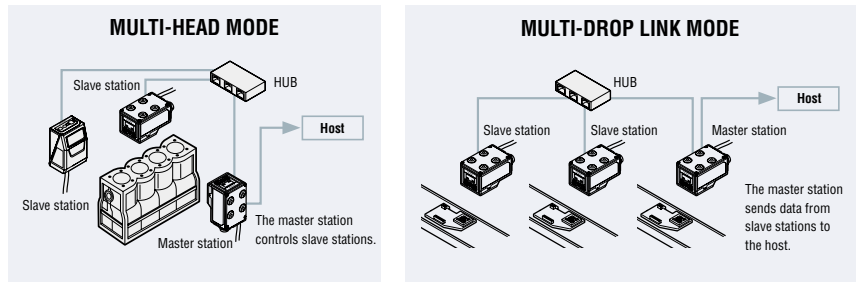

Communication and control via EtherNet/IP™ and PROFINET are also possible. (Only in multi-head mode)

PRODUCT CHANGEOVER FUNCTION

Up to 8 different configuration files can be stored in the reader's ROM. A simple command can switch configurations to allow reading under differing conditions such as reading distance, marking style, and code type.

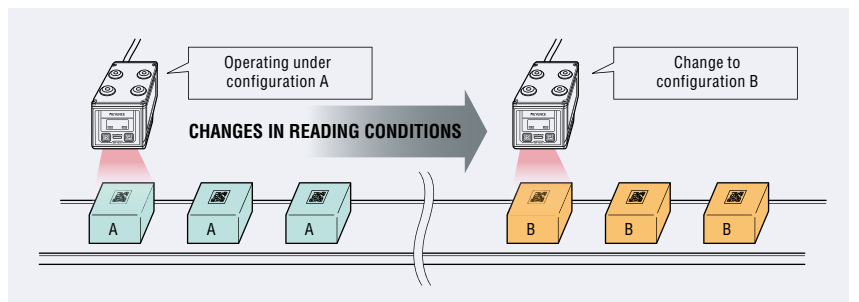

Switching instructions via EtherNet/IP™ and PROFINET are also possible.

HIGH-SPEED SEARCH

2D CODE SEARCH IN CAPTURED IMAGES

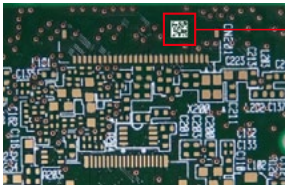

Binary processing enables immediate detection of 2D codes even if there is a code-like pattern in the field of view.

ADVANCED IDENTIFICATION

DEFECTIVE CODE POSITIONING PROGRAM

A newly developed defective code positioning program can identify four corners of a 2D code based on a similar code detection pattern, leading to a significant improvement in code detection performance.

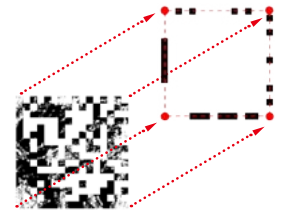

HIGH-LEVEL DECODING

CONTRAST ALGORITHM FOR LOCAL CONCENTRATION (CALC)

Our contrast algorithm for local concentrations divides a code into smaller pieces to perform binary processing using thresholds specified for each division. This enables accurate black/white classification without being affected by uneven print density.

CONVENTIONAL TECHNIQUE

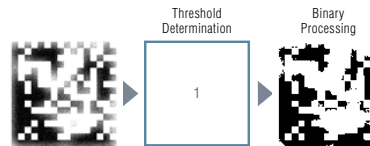

CALC TECHNIQUE



* The above illustration is only for reference and does not mean that a code is always divided into 16 parts.

AUTOMATIC SELECTION OF OPTIMAL READING CONDITIONS (PARAMETER BANK FUNCTION)

CUSTOM MODE ONLY

The reader will automatically alternate between registered parameter banks until the proper reading conditions are determined.

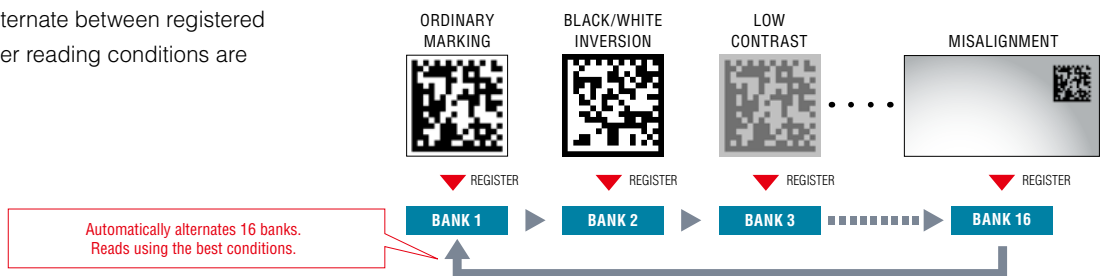

CONTINUOUS HIGH-SPEED READING

BUILT-IN DUAL CORE PROCESSOR

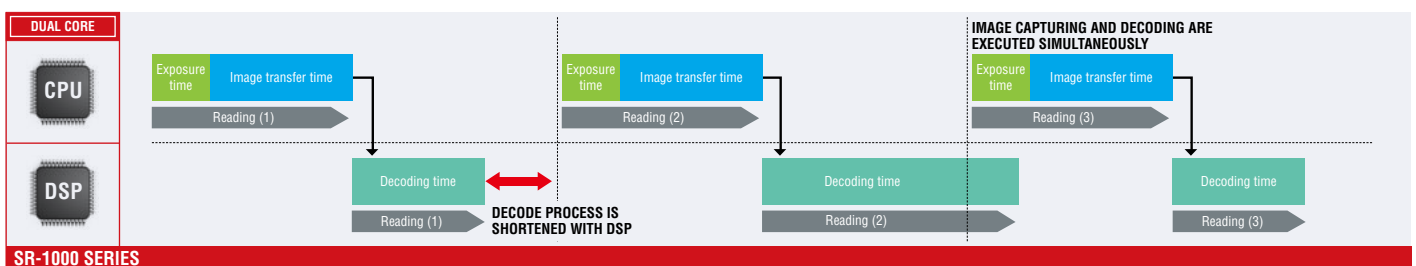
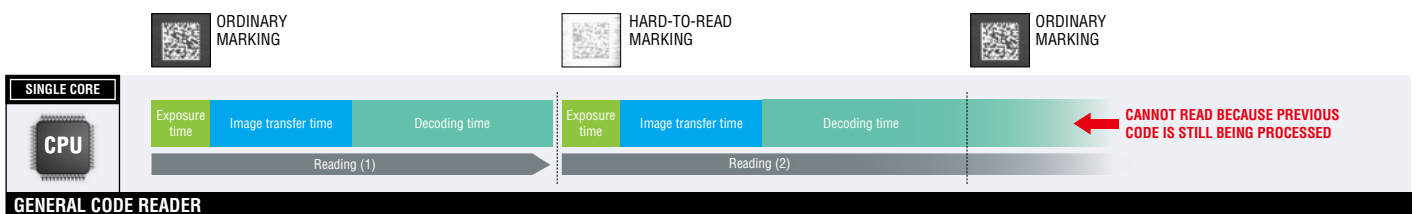

COMPATIBILITY WITH VARIOUS COMMUNICATION PROTOCOLS

Built-in EtherNet/IP™, PROFINET, and PLC link protocols make PLC connections even easier. In addition, general-purpose TCP/IP and FTP communications are also supported. With FTP communication, it is possible to transmit not only images but also text files of data.



Connection information for various PLC types can be found here: www.barcodereader.com/

CUSTOMIZABLE DATA OUTPUT FORMATTING

Thanks to customizable data output formats with the Data Edit function, programming corrections on the host side (PC, PLC, etc.) are not required, resulting in shorter setup time.

(EXAMPLES OF DATA EDIT FUNCTION IN USE)

Extracting specific characters



Adding information to image file names



Controlling output signals

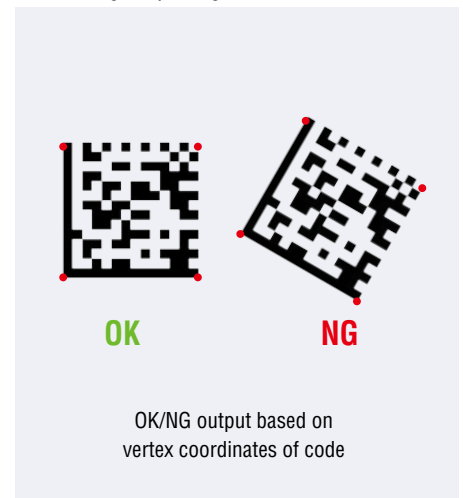

CONVENIENT SOFTWARE TOOLS

1. Specification and installation check

2. Operational testing and maintenance

3. Simple operations

Installation Guide

Checks for the proper reading distance, field of view, and line speed based on the code size.

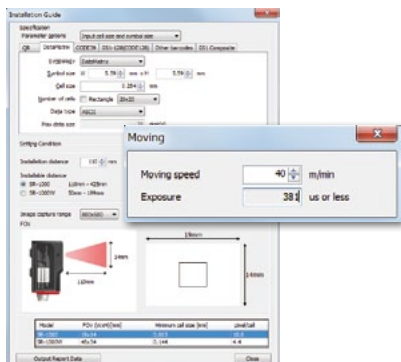

AutoID Terminal

Establishes direct communication with the code reader in order to isolate problems due to communication.

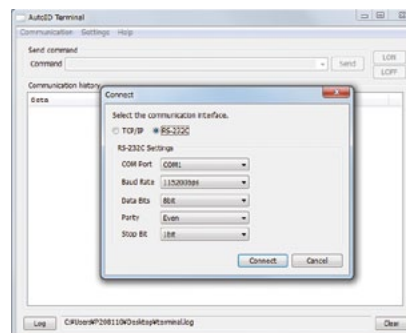

AutoID Keyboard Wedge

Outputs code data through the PC's keyboard interface. Both Windows and Mac versions are available.

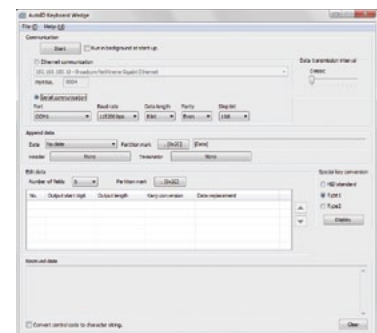

Improved reading of extremely small codes

HIGH RESOLUTION LENS ATTACHMENT **SR-10AH**

Capable of reading extremely small codes and codes printed on mirror finished surfaces.

Field of View: Increased

4.5x

When compared to conventional models
Mounting distance: 40 mm 1.57"
Image capture range: 800 × 600 pixels

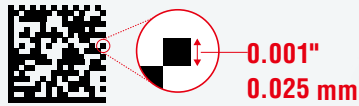
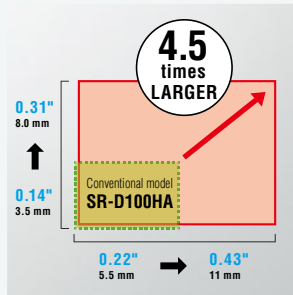

Variable installation distance for extremely small codes

When KEYENCE's test codes are used
Cell size 0.0016" 0.040 mm



Highly flexible mounting

When compared to conventional models

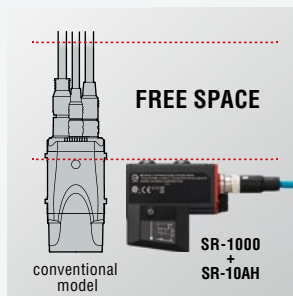

Automatic lighting control

When auto-tuning is enabled, lighting will automatically adjust to optimal settings based on current conditions

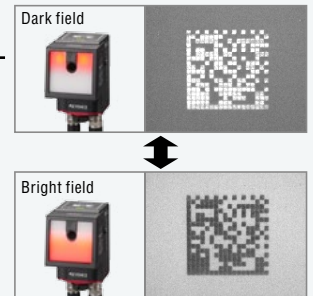

APPLICATION EXAMPLES

Micro-size sample (chip LED)

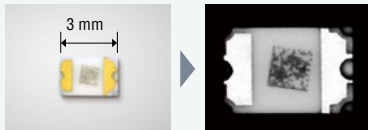

Mirrored surface (wafer)

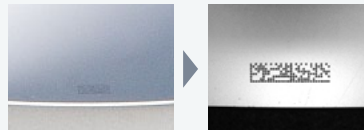

Metal (IC package)

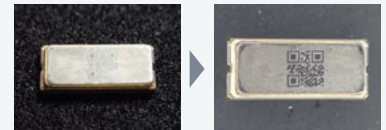

Superior reading of codes printed on mirror finished surfaces

REFLECTOR ATTACHMENT **SR-10AR**

By diffusing the reflected light from mirror finished surfaces, it's possible to achieve the same effect as using external lighting to create a clear image.



When **SR-10AR** is not used

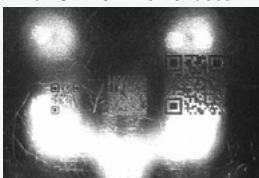

When **SR-10AR** is used



Reduces installation costs and setup time

ADJUSTABLE BRACKET **OP-88002**

This bracket allows the reader to be mounted in any position along either the vertical or horizontal axis.

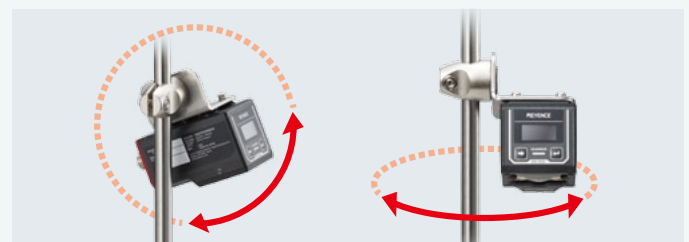
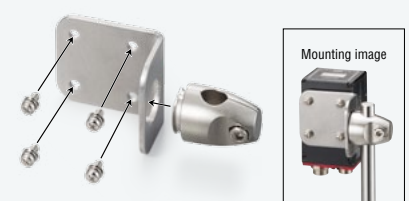

SR-1000 Series

Standard type
SR-1000



Wide-field type
SR-1000W



Mounting bracket
OP-87866



Adjustable bracket
OP-88002



High resolution lens attachment
SR-10AH



* SR-1000 only

Reflector attachment
SR-10AR



For details on optional accessories, see P. 13.

Cable

USB CABLE



USB cable plugA-miniB
2 m **6.56'**: **OP-51580**

CONTROL CABLE



NFPA79 compliant control cable
2 m **6.56'**: **OP-87353**
5 m **16.4'**: **OP-87354**
10 m **32.8'**: **OP-87355**



NFPA79 compliant control cable with D-sub 9-pin
2 m **6.56'**: **OP-87527**
5 m **16.4'**: **OP-87528**
10 m **32.8'**: **OP-87529**

ETHERNET CABLE



NFPA79 compliant Ethernet cable
2 m **6.56'**: **OP-87230**
5 m **16.4'**: **OP-87231**
10 m **32.8'**: **OP-87232**

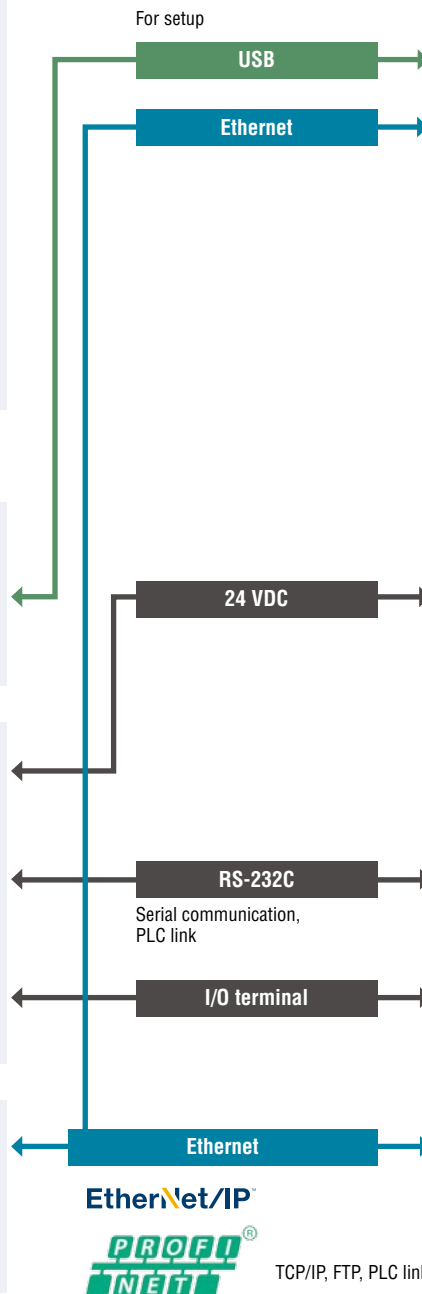

PC

PC for setup



Software **SR-H6W**



- AutoID Network Navigator
- AutoID Keyboard Wedge
- AutoID Terminal
- MultiMonitor
- FileView
- Various driver files
- EDS/GSDML files
- Sample Windows programs

POWER SUPPLY

24 VDC power supply



HOST

PC/Panel PC/Board PC



PLC

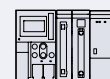

HMI [Touch panel]



READING RANGE CHARACTERISTICS [TYPICAL]

SR-1000

MINIMUM RESOLUTION

Distance	Unit (mm inch)	
	2D	Barcode
110 4.33"	0.063 0.002"	0.082 0.003"
110 to 140 4.33" to 5.51"	0.082 0.003"	
110 to 230 4.33" to 9.06"	0.14 0.006"	
110 to 300 4.33" to 11.81"	0.18 0.007"	0.11 0.004"
110 to 400 4.33" to 15.75"	0.24 0.009"	0.15 0.006"
110 to 600 4.33" to 23.62"	0.37 0.015"	0.22 0.009"
110 to 1000 4.33" to 39.37"	0.61 0.024"	0.37 0.015"

FIELD OF VIEW

Distance	Image capture range (1280 × 1024 pixels)		Image capture range (800 × 600 pixels)		Unit (mm inch)
	Width	Height	Width	Height	
110 4.33"	30 1.18"	24 0.94"	19 0.75"	14 0.55"	
140 5.51"	40 1.57"	32 1.26"	25 0.98"	18 0.71"	
230 9.06"	68 2.68"	54 2.13"	42 1.65"	32 1.26"	
300 11.81"	90 3.54"	72 2.83"	56 2.20"	42 1.65"	
400 15.75"	122 4.80"	97 3.82"	76 2.99"	57 2.24"	
600 23.62"	185 7.28"	148 5.83"	116 4.57"	87 3.43"	
1000 39.37"	312 12.28"	250 9.84"	195 7.68"	146 5.75"	

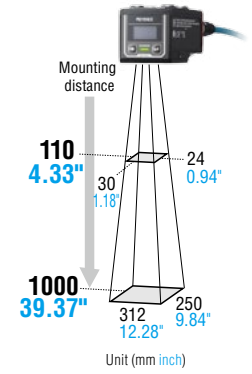

SR-1000W

MINIMUM RESOLUTION

Distance	Unit (mm inch)	
	2D	Barcode
50 1.97"	0.082 0.003"	0.082 0.003"
50 to 100 1.97" to 3.94"	0.14 0.006"	
50 to 150 1.97" to 5.91"	0.20 0.008"	
50 to 230 1.97" to 9.06"	0.30 0.012"	0.18 0.007"
50 to 300 1.97" to 11.81"	0.38 0.015"	0.23 0.009"
50 to 400 1.97" to 15.75"	0.51 0.020"	0.31 0.012"
50 to 600 1.97" to 23.62"	0.76 0.030"	0.45 0.018"

FIELD OF VIEW

Distance	Image capture range (1280 × 1024 pixels)		Image capture range (800 × 600 pixels)		Unit (mm inch)
	Width	Height	Width	Height	
50 1.97"	35 1.38"	28 1.10"	22 0.87"	16 0.63"	
100 3.94"	67 2.64"	54 2.13"	42 1.65"	31 1.22"	
150 5.91"	99 3.90"	79 3.11"	62 2.44"	46 1.81"	
230 9.06"	150 5.91"	120 4.72"	93 3.66"	70 2.76"	
300 11.81"	194 7.64"	155 6.10"	121 4.76"	91 3.58"	
400 15.75"	257 10.12"	206 8.11"	161 6.34"	120 4.72"	
600 23.62"	384 15.12"	307 12.09"	240 9.45"	180 7.09"	

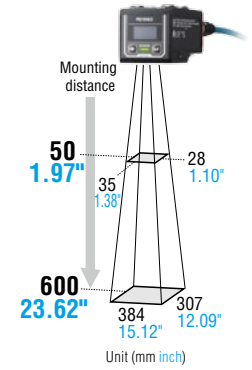

SR-1000 + SR-10AH

MINIMUM RESOLUTION

Distance	Unit (mm inch)	
	2D	Barcode
20 0.79"	0.025 0.001"	0.082 0.003"
20 to 30 0.79" to 1.18"	0.03 0.001"	
20 to 40 0.79" to 1.57"	0.04 0.002"	

FIELD OF VIEW

Distance	Image capture range (1280 × 1024 pixels)		Image capture range (800 × 600 pixels)		Unit (mm inch)
	Width	Height	Width	Height	
20 0.79"	11 0.43"	9 0.35"	7 0.28"	5 0.20"	
30 1.18"	15 0.59"	12 0.47"	9 0.35"	7 0.28"	
40 1.57"	19 0.75"	15 0.59"	11 0.43"	8 0.31"	

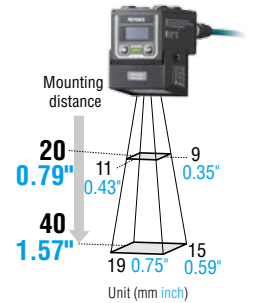

DIMENSIONS

Main unit
SR-1000/1000W

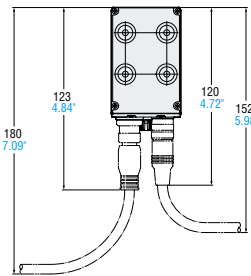
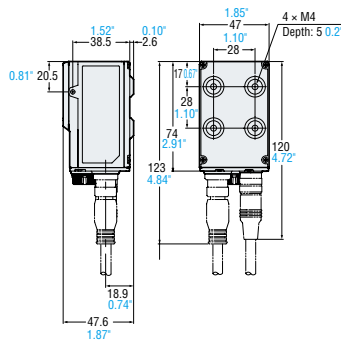

Adjustable bracket
OP-87866

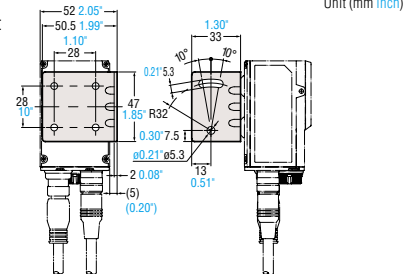

High resolution lens attachment
SR-10AH

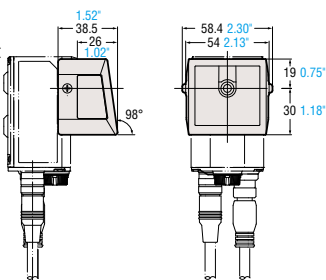

Reflector attachment
SR-10AR

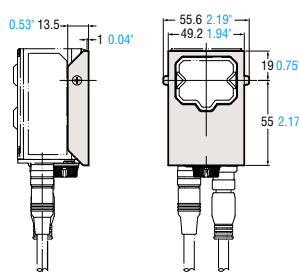

Adjustable bracket
OP-88002

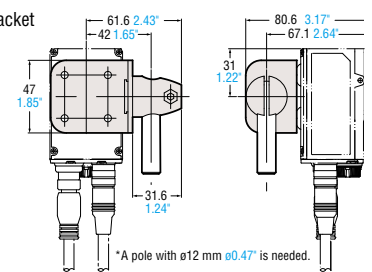

*A pole with ø12 mm ø0.47" is needed.

SPECIFICATIONS



Main unit

Model		SR-1000	SR-1000W	SR-1000+SR-10AH	
Type		Standard type	Wide-field type	When the high resolution lens attachment is installed	
Receiver	Sensor	CMOS Image Sensor			
	Number of pixels	1280 × 1024 pixels			
Light emitter	Illumination light source	High intensity red LED			
	Pointer light source	High intensity green LED			
Focus adjustment		Autofocus*			
Reading specifications	Supported symbol	2D	QR, MicroQR, DataMatrix (ECC200), GS1 DataMatrix, PDF417, MicroPDF417, GS1 Composite (CC-A/CC-B/CC-C)		
		Barcode	CODE39, ITF, 2of5(Industrial 2of5), COOP 2of5, NW-7 (Codabar), CODE128, GS1-128, GS1 DataBar, CODE93, JAN/EAN/UPC, Trioptic CODE39, CODE39 Full ASCII, Pharmacode		
	Minimum resolution	2D	0.063 mm 0.002"	0.082 mm 0.003"	0.025 mm 0.001"
		Barcode	0.082 mm 0.003"	0.082 mm 0.003"	0.082 mm 0.003"
	Reading distance	110 mm to 1000 mm 4.33" to 39.37"	50 mm to 600 mm 1.97" to 23.62"	20 mm to 40 mm 0.79" to 1.57"	
Field of view for reading	122 × 97 mm 4.80" × 3.82" (Typical example at 400 mm 15.75")	257 × 206 mm 10.12" × 8.11" (Typical example at 400 mm 15.75")	19 × 15 mm 0.75" × 0.59" (Typical example at 40 mm 1.57")		
I/O specifications	Control input	Number of inputs	2		
		Input type	Bidirectional voltage input		
		Maximum rating	26.4 VDC		
		Minimum ON voltage	15 VDC		
		Maximum OFF current	0.2 mA or less		
	Control output	Number of outputs	3		
		Output type	Photo MOS relay output		
		Maximum rating	30 VDC		
		Maximum load current	1 output: 50 mA or less, Total of 3 outputs: 100 mA or less		
		Leakage current when OFF	0.1 mA or less		
	Ethernet	Communication standard	IEEE 802.3 compliant, 10BASE-T/100BASE-TX		
		Supported protocol	TCP/IP, SNMP, FTP, BOOTP, MC protocol, Omron PLC link, KV STUDIO, EtherNet/IP™, PROFINET		
		Residual voltage when ON	1 V or less		
	Serial communication	Communication standard	RS-232C compliant		
		Transmission speed	9600, 19200, 38400, 57600, 115200 bps		
Supported protocol		No-protocol, MC protocol, SYSWAY, KV STUDIO			
USB	Communication standard	USB 2.0 Full Speed compliant			
Environmental resistance	Enclosure rating	IP65			
	Ambient temperature	0 to +45°C 32 to 113°F			
	Ambient storage temperature	-10 to +50°C 14 to 122°F			
	Relative humidity	35 to 85% RH (No condensation)			
	Storage ambient humidity	35 to 85% RH (No condensation)			
	Ambient luminance	Sunlight: 10000 lux, Incandescent lamp: 6000 lux, Fluorescent lamp: 2000 lux			
	Operating environment	No dust or corrosive gas present			
	Vibration	10 to 55 Hz Double amplitude 0.75 mm 0.030", 3 hours each in X, Y and Z directions			
Rating	Power voltage	24 VDC ±10%			
	Current consumption	Approx. 700 mA			
Weight		Approx. 200 g	Approx. 250 g		

* The focal position can be adjusted automatically during installation.
 • SR-1000N and SR-1000WN are available as supported models for India.

Setup software (AutoID Network Navigator)

Model	SR-H6W
Supported OS	Windows 10 Professional or later, 32 bit/64 bit Windows 8 Professional or later, 32 bit/64 bit (Except for Windows RT) Windows 7 Professional or later, 32 bit/64 bit Windows Vista Business/Ultimate SP2 or later, 32 bit*
Running environment	Processor: 2.0 GHz or better Memory: 1 GB (32 bit)/2 GB (64 bit) DVD-ROM drive (during installation) Screen resolution: 1024 × 768 or better

- * SR-2000/G100 products do not support Windows Vista.
- .NET Framework 3.5 SP1 or later installed
- Internet connectivity for Windows 8/10 machines with .NET 3.5 installed
- Control panel operability for Windows 8/10 machines with .NET 3.5 installed

SR SERIES LINEUP



Handheld DPM Code Reader
SR-G100



Ultra-compact 1D and 2D Code Reader
SR-700 Series



High Performance Compact 1D and 2D Code Reader
SR-750 Series



CALL TOLL FREE TO CONTACT YOUR LOCAL OFFICE
1-888-KEYENCE
 1 - 8 8 8 - 5 3 9 - 3 6 2 3

www.keyence.com

SAFETY INFORMATION
 Please read the instruction manual carefully in order to safely operate any KEYENCE product.

CONTACT YOUR NEAREST OFFICE FOR RELEASE STATUS

KEYENCE CORPORATION OF AMERICA

Head Office 500 Park Boulevard, Suite 200, Itasca, IL 60143, U.S.A. PHONE: +1-201-930-0100 FAX: +1-855-539-0123 E-mail: keyence@keyence.com

AL Birmingham	CA San Jose	CO Denver	IL Chicago	MI Detroit	MO St. Louis	NC Raleigh	PA Philadelphia	TN Nashville	WI Milwaukee
AR Little Rock	CA Cupertino	FL Tampa	IN Indianapolis	MI Grand Rapids	NJ Elmwood Park	OH Cincinnati	PA Pittsburgh	TX Austin	
AZ Phoenix	CA Los Angeles	GA Atlanta	KY Louisville	MN Minneapolis	NY Rochester	OH Cleveland	SC Greenville	TX Dallas	
CA San Francisco	CA Irvine	IA Iowa	MA Boston	MO Kansas City	NC Charlotte	OR Portland	TN Knoxville	WA Seattle	

KEYENCE CANADA INC.

Head Office PHONE: +1-905-366-7655 FAX: +1-905-366-1122 E-mail: keyencecanada@keyence.com
 Montreal PHONE: +1-514-694-4740 FAX: +1-514-694-3206 Windsor PHONE: +1-905-366-7655 FAX: +1-905-366-1122

KEYENCE MEXICO S.A. DE C.V.

PHONE: +52-55-8850-0100 FAX: +52-81-8220-9097
 E-mail: keyencemexico@keyence.com

The information in this publication is based on KEYENCE's internal research/evaluation at the time of release and is subject to change without notice.
 Company and product names mentioned in this catalog are either trademarks or registered trademarks of their respective companies.
 The specifications are expressed in metric units. The English units have been converted from the original metric units.
 Copyright (c) 2017 KEYENCE CORPORATION. All rights reserved.