

# KEYENCE

**NEW** Handheld DPM Code Reader  
SR-G100

EtherNet/IP<sup>™</sup> **PROFINET**<sup>®</sup> CE **SP**<sup>®</sup><sub>US</sub>

## THE NEXT GENERATION OF HANDHELD CODE READERS



**SR-G100**

# COMMON CHALLENGES FACED BY HANDHELD DPM CODE READERS

## SLOW

Reading takes time, which causes operations to fall behind and leads to downed production lines



## UNSTABLE

Because reading time is inconsistent, mistakes such as duplicated or skipped reads may occur

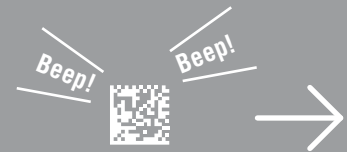

## VARIABLE

Readings differ from person to person due to varying levels of understanding

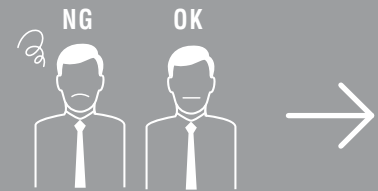

## DIFFICULT

Figuring out the best settings takes a long time or can sometimes even be impossible



# THESE ISSUES AREN'T A PROBLEM FOR THE SR-G100

**HIGH-SPEED  
READING**

**STABLE  
READING**

**EASY  
OPERATION**

**EASY  
CONFIGURATION**



**NEW**

Handheld DPM Code Reader  
**SR-G100**

# HIGH-SPEED READING REGARDLESS OF OPERATOR



## WIRELESS COMMUNICATION IMPROVES FLEXIBILITY

Not only does being wireless improve the SR-G100's general flexibility, it also solves various problems that would otherwise be impossible to overcome.



No need to spend time on wiring

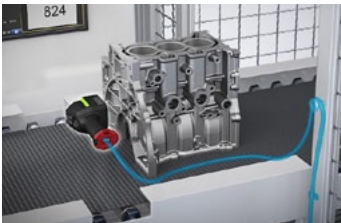

No interference from cables



No need to worry about damaged cables

**BUILT-IN FUNCTION BUTTON**

**EASILY CUSTOMIZABLE SETTINGS**

Automatic tuning is done simply by pushing the function button and reading a code. Use the device on site without the need to carry around a PC.



**Assess stability of reading and communication**

- Reading rate testing
- Radio wave testing



**ERGONOMIC SHAPE THAT REINFORCES OPTIMAL POSITIONING**

**CENTER-OF-GRAVITY DESIGN**

By naturally inducing a flat position, the SR-G100 reduces the impact of variations between users as well as variations in code marking styles. This makes it possible for anyone to read codes consistently and stably.



**MULTI-LIGHTING CONTROL FUNCTION**

**AUTOMATIC SELECTION OF OPTIMAL LIGHTING**

**Polarizing illumination**



Removes glare from metal, black resin, etc.

**Multi-angle lights + partial lighting**



Reads DPM codes on metals including cylinders and cast surfaces

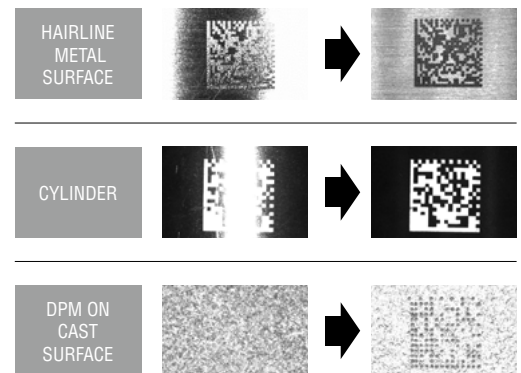

**CAPABLE OF HANDLING CHALLENGING CODES**

Code correction algorithms, developed for the SR-1000 Series of fixed mount code readers, have been optimized specifically for use with handheld code readers. This allows an ideal balance between reading consistency and speed.

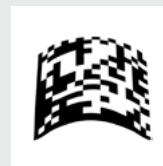

Distorted codes on curved surfaces



Codes marked on milled surfaces



Codes marked on surfaces with projections and depressions

**COMPATIBLE WITH VARIOUS COMMUNICATION PROTOCOLS**

Support for EtherNet/IP™, PROFINET, and PLC link improves PLC compatibility. This allows for interaction with fixed mount code readers installed on equipment or on production lines. In addition, the OUT signal (OK, ERROR, BUSY, etc.) from the communication unit (SR-LR1) makes synchronization with the PLC even easier.

**Verification and tracking of main and sub parts**

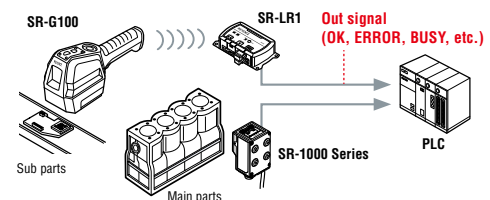



# CUSTOMIZABLE SETTINGS USING EASY CONFIGURATION SOFTWARE

AutoID Network Navigator **SR-H6W** NEW

- Easy connection via USB
- Automatic tuning at the push of a button
- Up to 12 different groups of settings can be stored
- Real-time reading confirmation using Live View

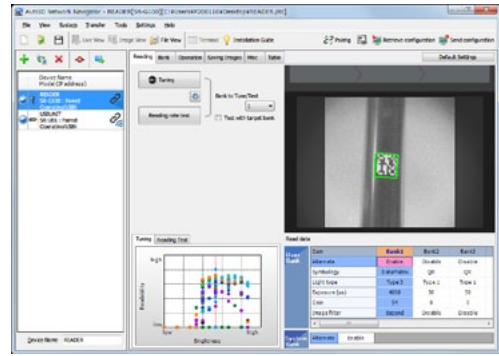

## DIMENSIONS

Unit: mm

### Handheld DPM Code Reader **SR-G100**

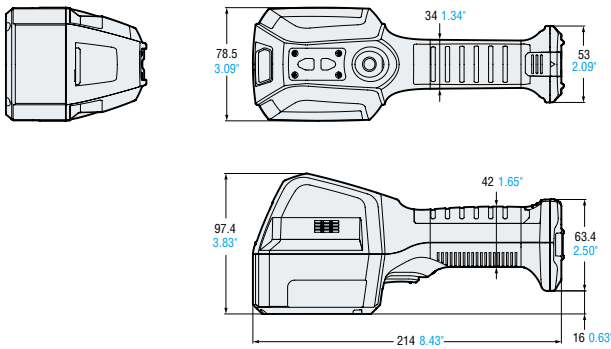

### SR-G100 Cable **SR-PU1**

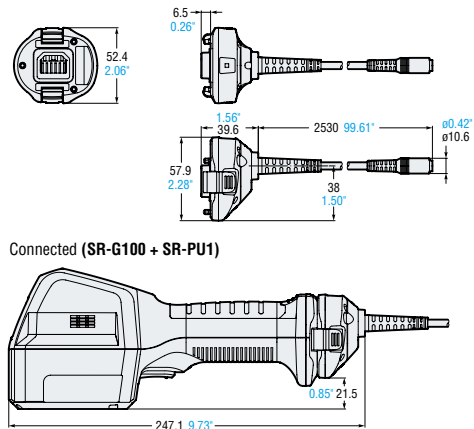

### Holder **SR-HL1**

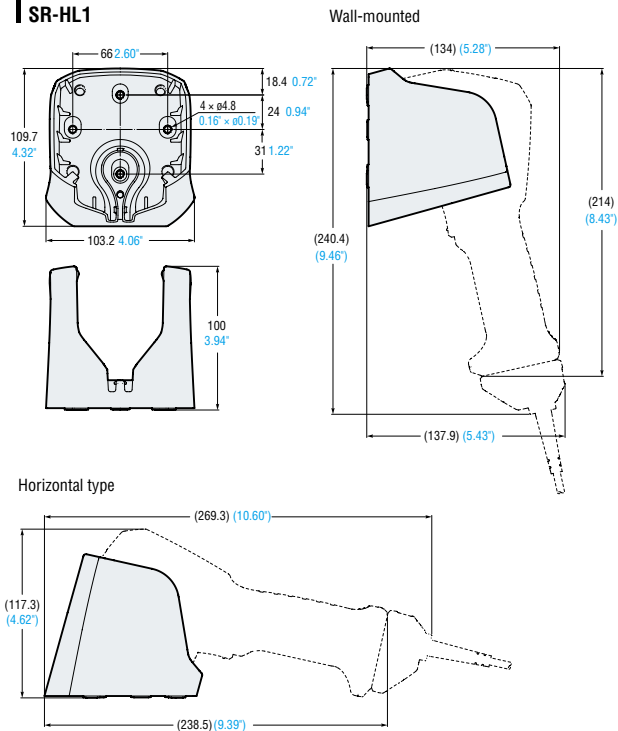

### Communication unit (Ethernet & RS-232C) **SR-LR1**

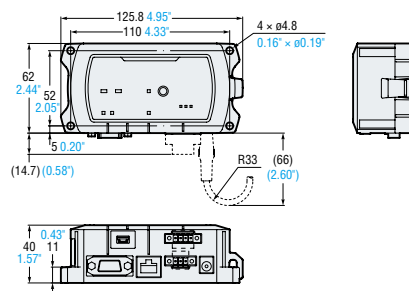

### 4-in-line charging unit **SR-CG14**

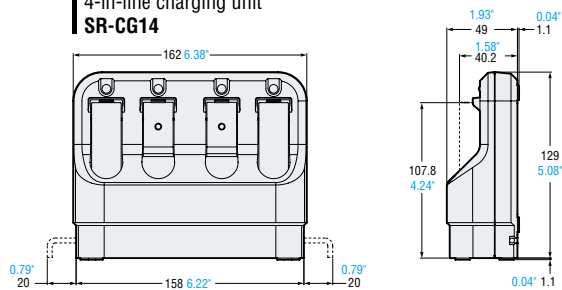

## FIELD OF VIEW FOR READING (TYPICAL)

**2D code** Unit: mm inch

Distance	Minimum resolution	Horizontal	Vertical
30 1.18"	0.127 0.005"	45 1.77"	45 2.56"
70 2.76"	0.25 0.009"	65 2.56"	65 2.56"
110 4.33"	0.5 0.020"	85 3.35"	85 3.35"

**Barcode** Unit: mm inch

Distance	Minimum resolution	Horizontal	Vertical
80 3.15"	0.25 0.010"	99 3.90"	70 2.76"
120 4.72"	0.5 0.020"	127 5.00"	90 3.54"
200 7.87"	1 0.039"	184 7.24"	129 5.08"

### QUICK SETUP CODE

Settings on the main unit can be changed using codes created through the setup software.



(Ex.: Initialization code)

**STEP 1 SELECT A CONNECTION INTERFACE**

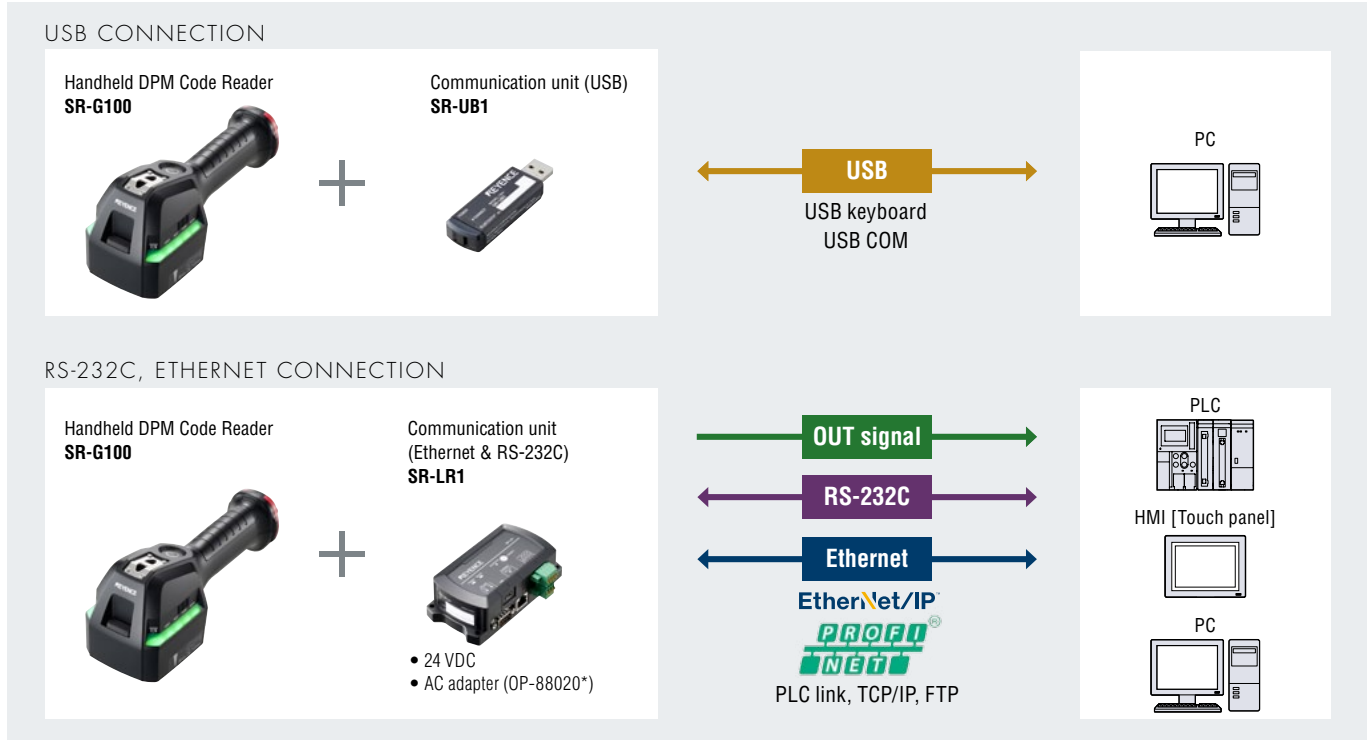

**STEP 2 SELECT A CHARGING/POWER METHOD**

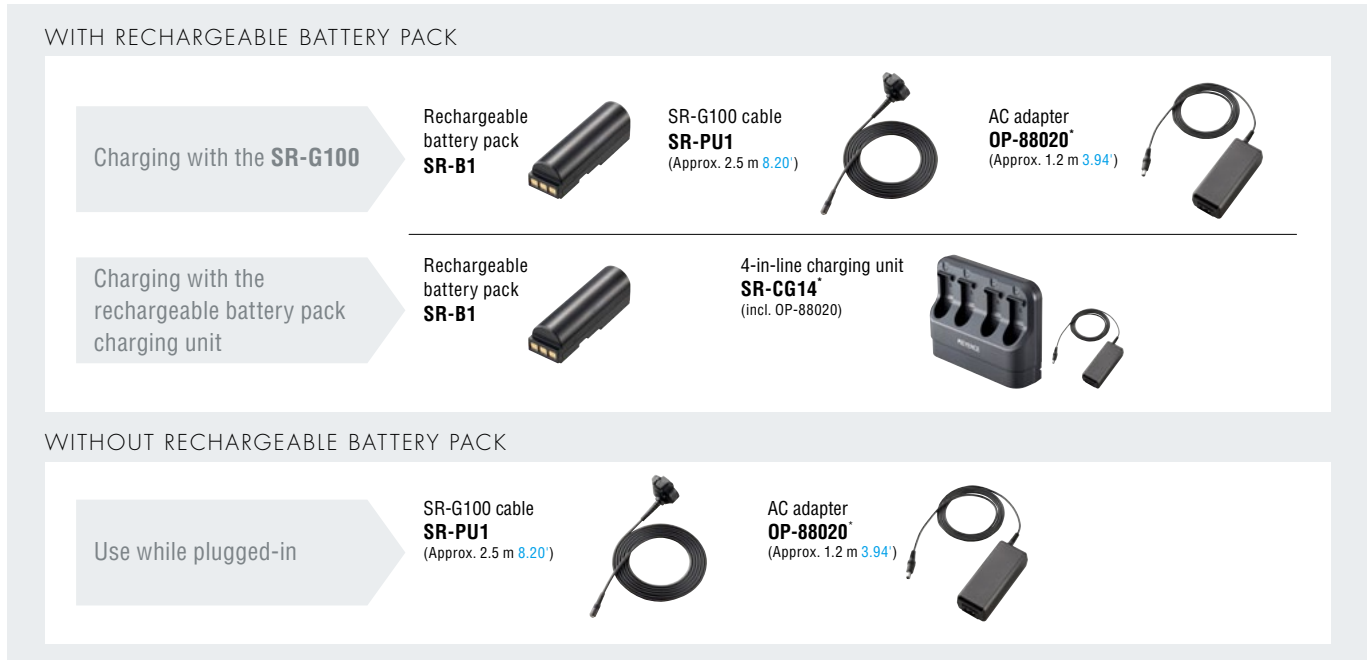

\* A separate AC cable is required with OP-88020 and SR-CG14 products.

**AC CABLE LIST**

(Approx. 2 m 6.56)

**OP-99022** (USA, Canada) **OP-99102** (Mexico) **OP-99062** (UK) **OP-99032** (Germany, France, Italy, Belgium)  
**OP-99042** (China) **OP-99112** (Thailand) **OP-99012** (Japan)

**OTHER OPTIONAL ACCESSORIES AND SETUP SOFTWARE**

Holder **SR-HL1**  
Supports both flat and wall-mounted positions

USB cable **OP-51580**  
SR-G100/SR-LR1 for setup

Setup software **SR-H6W**

# SPECIFICATIONS



## Handheld DPM Code Reader

Model		SR-G100	
Receiver	Sensor	CMOS image sensor	
	Number of pixels	900 × 900 pixels (2D code), 1280 × 900 pixels (Barcode)	
Light emitter	illumination light source	High-intensity red LED, High intensity blue LED	
Reading specifications	Supported symbol	2D code	QR, MicroQR, DataMatrix (ECC200), GS1 DataMatrix, PDF417, MicroPDF417, GS1 Composite (CC-A/CC-B/CC-C)
		Barcode	CODE39, ITF, 2of5 (Industrial 2of5), COOP 2of5, NW-7 (Codabar), CODE128, GS1-128, GS1 DataBar, CODE93, JAN/EAN/UPC, Trioptic CODE39, CODE39 Full ASCII, Pharmacode
	Minimum resolution	2D code	0.127 mm 0.005"
		Barcode	0.1 mm 0.004"
	Focal distance	30 mm 1.18"	
Communication specifications	Wireless communication	Bluetooth Ver. 2.1 + EDR Class 2	
	Wireless communication distance	Approx. 10 m 32.81' (line-of-sight)	
	Setup communication	USB 2.0 Full Speed	
Environmental resistance	Enclosure rating	IP54	
	Ambient temperature	0 to +45°C 32 to +113°F / When charging: 0 to +40°C 32 to +104°F	
	Ambient storage temperature	-10 to +50°C 14 to +122°F	
	Relative humidity	35 to 95% RH (No condensation)	
	Ambient storage humidity	35 to 95% RH (No condensation)	
	Ambient light	Sunlight: 10000 lux, Incandescent lamp: 6000 lux, Fluorescent lamp: 2000 lux	
	Operating environment	No dust or corrosive gas present	
	Drop resistance*	2.0 m 6.56', 50 times	
Rating	Power consumption	Approx. 8.5 W	
Dimensions		214 × 78.5 × 97.4 mm 8.43" × 3.09" × 3.83"	
Weight		Approx. 375 g (incl. rechargeable battery pack)	
Continuous usage time (Central value)		Approx. 10 hours (reading count: 10000)	
Charging time		Approx. 4.5 hours	

\* This is a test value and is not guaranteed.

## Communication unit (USB)

Model		SR-UB1
Communication specifications	Wireless communication	Bluetooth Ver. 2.1 + EDR Class 2
	Wireless communication distance	Approx. 10 m 32.81' (line-of-sight)
	USB communication	USB 2.0 Full Speed
	Interface	USB-COM, USB keyboard
Environmental resistance	Ambient temperature	0 to +45°C 32 to +113°F
	Ambient storage temperature	-10 to +50°C 14 to +122°F
	Relative humidity	35 to 95% RH (No condensation)
	Ambient storage humidity	35 to 95% RH (No condensation)
Rating	Current consumption	Approx. 80 mA
Dimensions		20.6 × 11.2 × 65.4 mm 0.81" × 0.44" × 2.57"
Weight		Approx. 15 g
Supported OS		Microsoft Windows 8 Professional or later 32bit/64bit (Except for Windows RT), Microsoft Windows 7 Professional or later 32bit/64bit

## Communication unit (Ethernet & RS-232C)

Model		SR-LR1
Communication specifications	Wireless communication	Bluetooth Ver. 2.1 + EDR Class 2
	Wireless communication distance	Approx. 10 m 32.81' (line-of-sight)
	RS-232C	9600, 19200, 38400, 57600, 115200 bps No-protocol, MC protocol, SYSWAY, KV STUDIO
	Ethernet	IEEE 802.3, 10BASE-T / 100BASE-TX TCP/IP, FTP, MC protocol, Omron PLC link, KV STUDIO, EtherNet/IP™, PROFINET
Control output	Number of points	3
	Output format	Photo MOS relay
	Maximum rating	30 VDC, 100 mA
	Leakage current when OFF	0.1 mA or less
	Residual voltage when ON	1 V or less
Environmental resistance	Ambient temperature	0 to +45°C 32 to +113°F
	Ambient storage temperature	-10 to +50°C 14 to +122°F
	Relative humidity	35 to 95% RH (No condensation)
	Ambient storage humidity	35 to 95% RH (No condensation)
Rating	Power voltage / current consumption	24 VDC ±10% / Approx. 120 mA, or use dedicated AC adapter (12 VDC) / Approx. 230 mA
Dimensions		62 × 125.8 × 40 mm 2.44" × 4.95" × 1.57"
Weight		Approx. 160 g

## AC adapter

Model	OP-88020
Rated input	100 to 240 VAC, 50/60 Hz
Rated output	12 VDC, 1.5 A max.
Dimensions	104 × 43 × 31 mm 4.09" × 1.69" × 1.22" (excl. cable area)
Weight	Approx. 125 g

\* Using SR-PU1 or SR-LR1. AC cable required separately.

## Setup software (AutoID Network Navigator)

Model	SR-H6W
Supported OS	Windows 10 Professional or later, 32 bit/64 bit Windows 8 Professional or later, 32 bit/64 bit (Except for Windows RT) Windows 7 Professional or later, 32 bit/64 bit Windows Vista Business/Ultimate SP2 or later, 32 bit*
Running environment	Processor: 2.0 GHz or better, Memory: 1 GB (32 bit)/2 GB (64 bit), DVD-ROM drive (during installation), Screen resolution: 1024 × 768 or better

\* SR-2000/G100 products do not support Windows Vista.

• .NET Framework 3.5 SP1 or later installed • Internet connectivity for Windows 8/10 machines with .NET 3.5 installed • Control panel operability for Windows 8/10 machines with .NET 3.5 installed



CALL TOLL FREE

TO CONTACT YOUR LOCAL OFFICE  
**1-888-KEYENCE**  
1 - 8 8 8 - 5 3 9 - 3 6 2 3

[www.keyence.com](http://www.keyence.com)



### SAFETY INFORMATION

Please read the instruction manual carefully in order to safely operate any KEYENCE product.

CONTACT YOUR NEAREST OFFICE FOR RELEASE STATUS

## KEYENCE CORPORATION OF AMERICA

Head Office 500 Park Boulevard, Suite 200, Itasca, IL 60143, U.S.A. PHONE: +1-201-930-0100 FAX: +1-855-539-0123 E-mail: [keyence@keyence.com](mailto:keyence@keyence.com)

<b>AL</b> Birmingham	<b>CA</b> San Jose	<b>CO</b> Denver	<b>IL</b> Chicago	<b>MI</b> Detroit	<b>MO</b> St. Louis	<b>NC</b> Raleigh	<b>PA</b> Philadelphia	<b>TN</b> Nashville	<b>WI</b> Milwaukee
<b>AR</b> Little Rock	<b>CA</b> Cupertino	<b>FL</b> Tampa	<b>IN</b> Indianapolis	<b>MI</b> Grand Rapids	<b>NJ</b> Elmwood Park	<b>OH</b> Cincinnati	<b>PA</b> Pittsburgh	<b>TX</b> Austin	
<b>AZ</b> Phoenix	<b>CA</b> Los Angeles	<b>GA</b> Atlanta	<b>KY</b> Louisville	<b>MN</b> Minneapolis	<b>NY</b> Rochester	<b>OH</b> Cleveland	<b>SC</b> Greenville	<b>TX</b> Dallas	
<b>CA</b> San Francisco	<b>CA</b> Irvine	<b>IA</b> Iowa	<b>MA</b> Boston	<b>MO</b> Kansas City	<b>NC</b> Charlotte	<b>OR</b> Portland	<b>TN</b> Knoxville	<b>WA</b> Seattle	

## KEYENCE CANADA INC.

Head Office PHONE: +1-905-366-7655 FAX: +1-905-366-1122 E-mail: [keyencecanada@keyence.com](mailto:keyencecanada@keyence.com)  
Montreal PHONE: +1-514-694-4740 FAX: +1-514-694-3206 Windsor PHONE: +1-905-366-7655 FAX: +1-905-366-1122

## KEYENCE MEXICO S.A. DE C.V.

PHONE: +52-55-8850-0100 FAX: +52-81-8220-9097  
E-mail: [keyencemexico@keyence.com](mailto:keyencemexico@keyence.com)

The information in this publication is based on KEYENCE's internal research/evaluation at the time of release and is subject to change without notice.

Company and product names mentioned in this catalog are either trademarks or registered trademarks of their respective companies.

The specifications are expressed in metric units. The English units have been converted from the original metric units.

Copyright (c) 2017 KEYENCE CORPORATION. All rights reserved.

KA1-1017

SRG100-KA-C2-US 1057-1 611F12