

SENSING IONIZER General Catalog

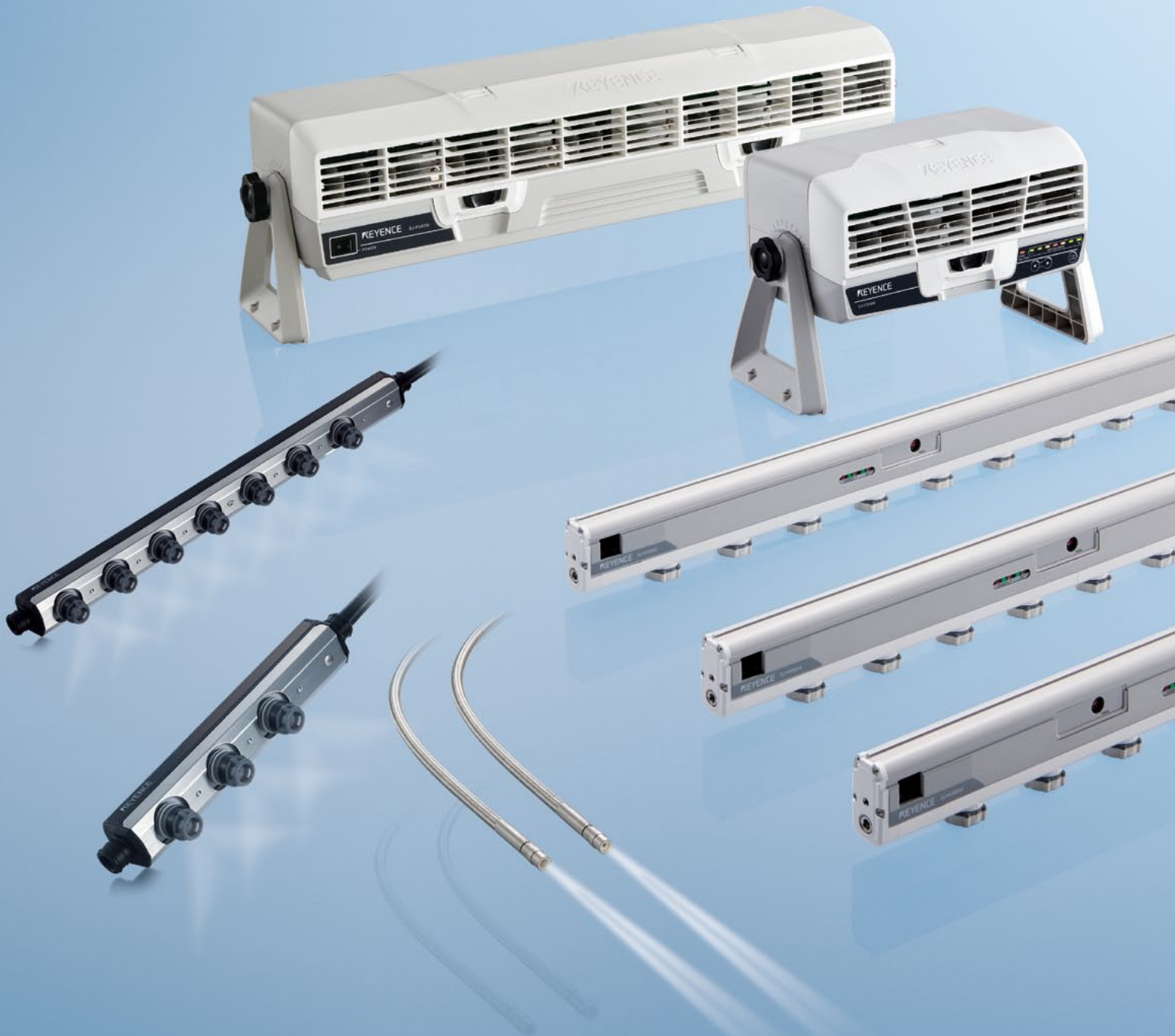



SELECT THE BEST TYPE FOR YOUR APPLICATION AND MOUNTING LOCATION

KEYENCE offers a wide variety of models to meet the needs of a new era of improved productivity and quality in the workplace.

High-speed static elimination and high-precision ion balance

Pulse AC method

The SJ Series has adopted the pulse AC method that applies alternating high voltage to the electrode probe, producing ions of both polarities. Compared to the conventional AC method, the amount of ions generated is higher and the oscillating frequency can be changed. Therefore, the pulse AC method can be used in all conditions, from high-speed moving applications to static elimination of a work area.

AC method

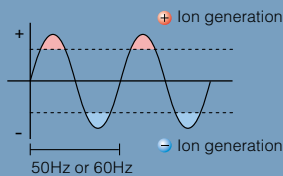

There are periods when no positive (+) or negative (-) ions are generated, therefore the positive (+) and negative (-) ions are distributed separately and cannot eliminate static effectively.

Pulse AC method

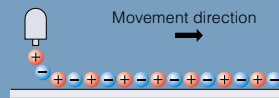
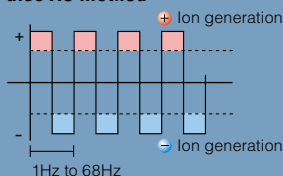

The positive (+) and negative (-) ions are uniform and provide ideal static elimination. (At 33 Hz)

High-precision ion balance with the I.C.C. method

By sensing the ion current generated by the potential difference between the electrode probe and the amount of charge for a workpiece, this method performs calculations and controls the supplied ions based on the amount of charge to achieve rapid static elimination. The I.C.C. method provides high-precision ion balance control for rapid and effective static elimination.

Conventional method

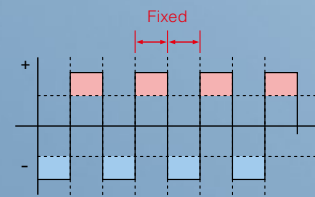

I.C.C. method

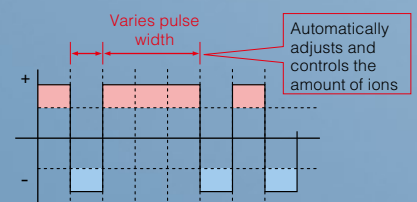

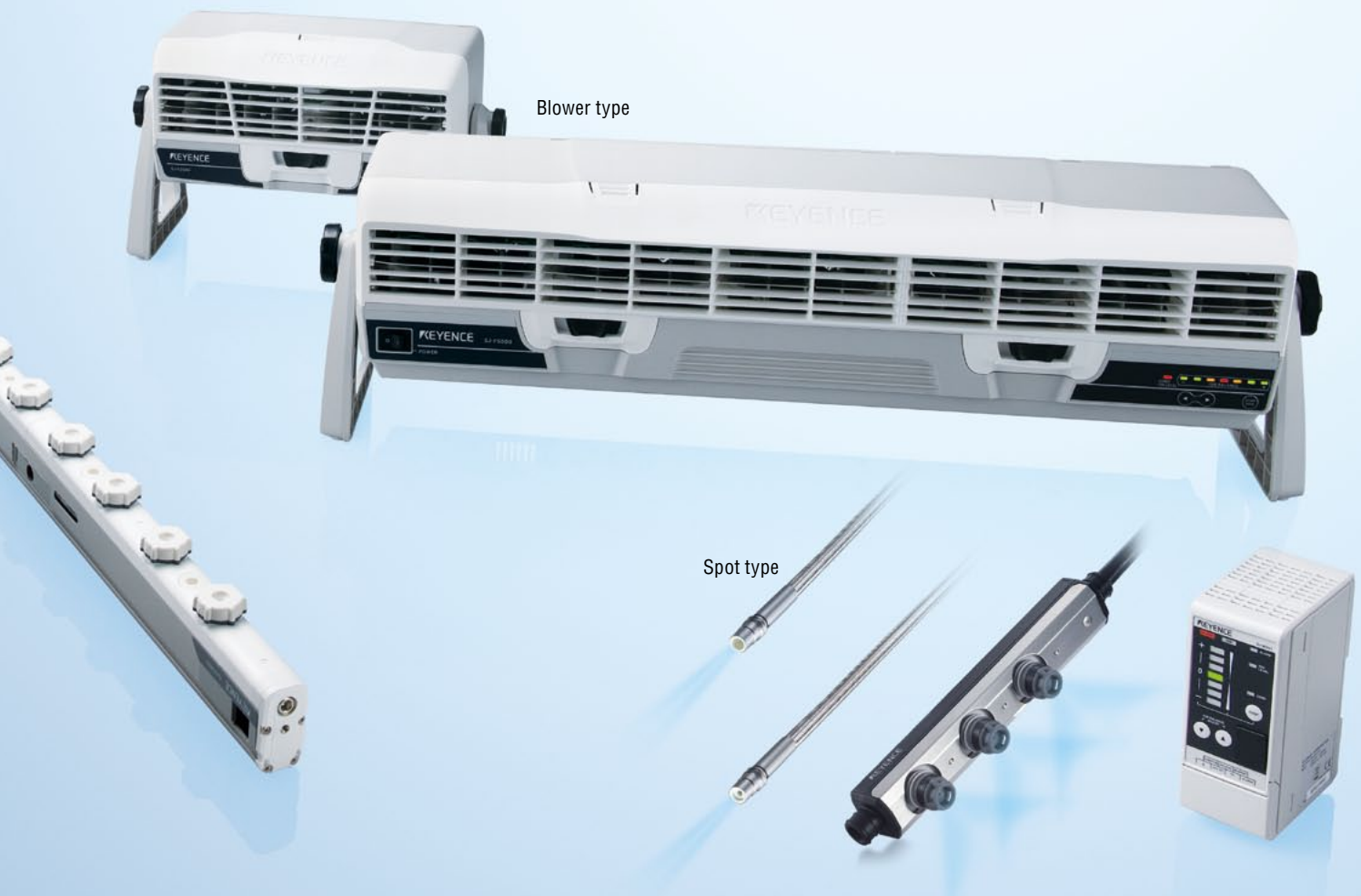

Blower type

Spot type

No need for complicated sensor installation

I.C.C. control with built-in automatic sensing and feedback

Automatically control ion balance

The I.C.C. method supplies the optimal balance of ions according to the detected charge, so it does not require any additional calibration during installation or maintenance. This provides quick and effective static elimination.

No need for initial adjustment of ion balance

Since the amount of generated ions is controlled automatically, the ion balance does not need to be adjusted.

Ions supplied for high-speed static elimination

Because the ions are supplied according to the amount of charge, high-speed static elimination is possible.

Constant monitoring of ion balance for long-term stability

Automatic adjustment compensates for deterioration in ion balance due to build-up on the electrode probe.

Maintenance results for static elimination time using I.C.C. (Example)

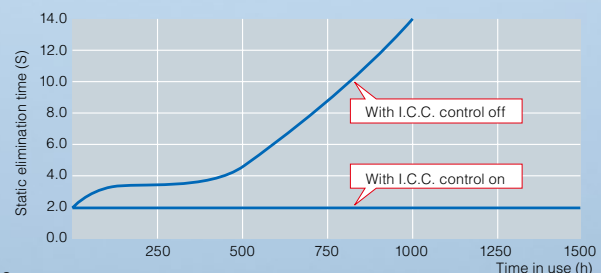

Start measurement

* Measurement conditions for the KEYENCE comparison test

Voltage: +1000 V → +100 V,
Plate monitor: 150 mm x 150 mm (5.91" x 5.91")
(20 pF) Installation distance: 300 mm (11.81")

Built-in Display

Sensing ionizer

It is difficult to know whether a static eliminator is working properly since static is invisible. The built-in display found on KEYENCE static eliminators allows users to monitor elimination status and determine the appropriate time for maintenance.

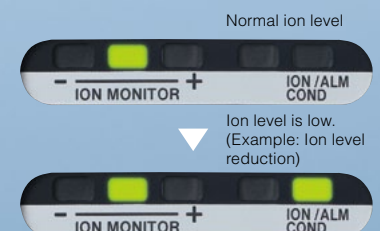

Static eliminators are suitable for almost any industry

WIDE AREA

BAR TYPE

STATIC ELIMINATION IN WIDE AREAS

TYPICAL APPLICATIONS

- Prevention of foreign material adhesion to heat seals
- Static elimination in air shower spaces
- Prevention of dust adhesion to sheet materials
- Elimination of sawdust when cutting building materials
- Prevention of dust adhesion to bumpers

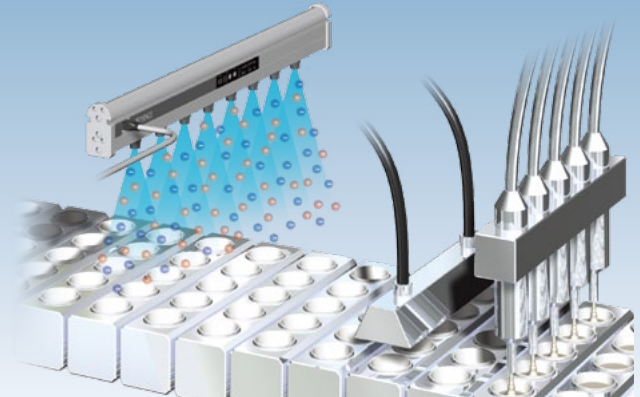

With the combination of the KEYENCE designed pulse AC method and I.C.C. method, the SJ-H Series enables uniform static elimination at high speeds. Bar type static eliminators are suitable for applications that require stable static elimination over a wide area, such as prevention of static electricity during part transfer, prevention of dust adhesion to sheet materials, and static elimination in a workspace.

MEDIUM AREA

BLOWER TYPE

STATIC ELIMINATION IN MEDIUM SIZED AREAS

TYPICAL APPLICATIONS

- Static elimination when filling pharmaceuticals
- Static elimination in labeling processes
- Static elimination from parts feeders
- Prevention of film adhesion in cutting processes
- Prevention of dust adhesion to resin bottles

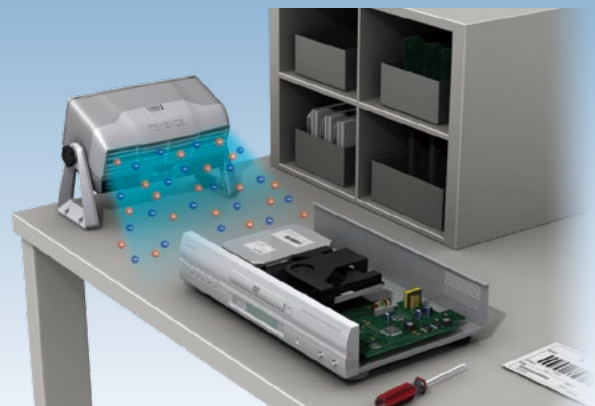

The blower-type static eliminators carry ions generated by corona discharge via the air from the blower fans. Electrostatic charge is eliminated from a charged object by this positive and negative ion-carrying air. The SJ Series blower type is suitable for static elimination of an object with uneven surfaces. It can even be used on the human body. Because the human body is similar to a conductor, the blower type provides static elimination effects simply by applying the ion-carrying air to the human body.

NARROW AREA

SPOT TYPE

STATIC ELIMINATION IN NARROW AREAS

TYPICAL APPLICATIONS

- Static elimination of pillow type packaging machines
- Static elimination in chip pick-and-place processes
- Prevent mixing of foreign materials in shrink packaging
- Elimination of dust from resin components
- Static elimination to prevent parts from remaining in molds

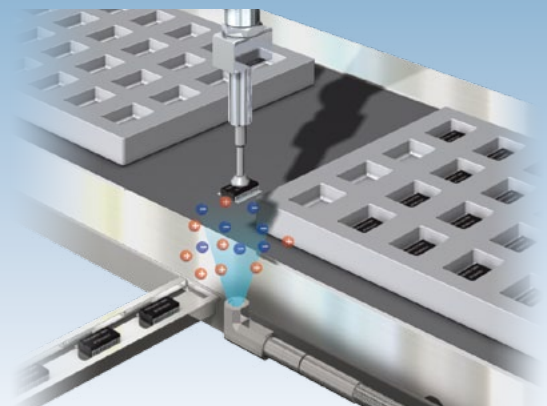

With their small size, the SJ Series spot-type static eliminators can be used to eliminate static electricity from a focused point. Combined with a high air supply pressure, the spot-type static eliminators can be used to blow off dust while eliminating static electricity, thus preventing re-adhesion of dust.

BAR TYPE



Static elimination of films

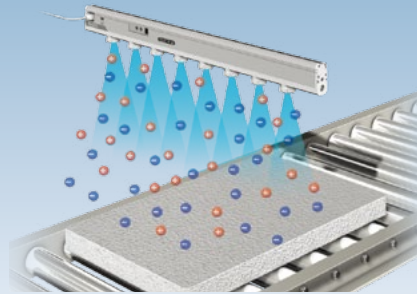

Static elimination of building material boards

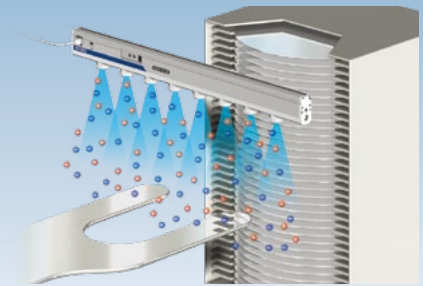

Static elimination of wafers

Static elimination for wide areas, covering both short and long operating distances

For static elimination of a target, the type of static eliminator used varies depending on target size, static elimination time required, and the static eliminator's operating distance. The SJ-H Series enables static elimination under user-required conditions by using an air purge function, and by adjusting the positive/negative ion generation frequency.

BLOWER TYPE

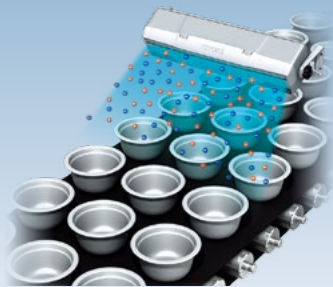

Static elimination of food containers

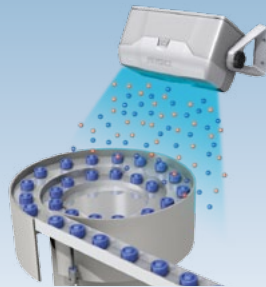

Static elimination of parts feeders

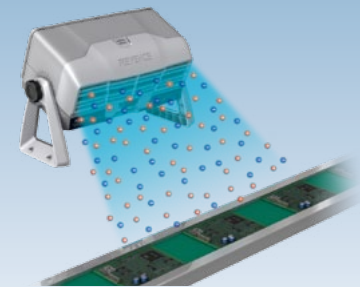

Static elimination on ECU circuit boards

Simple Installation

The SJ Series blower-type static eliminators are suitable for many applications, ranging from bench-top use to fixed mount installation. Since it delivers ions via air from the built-in blower, the static elimination area and speed can be determined by simply adjusting the air capacity. Even for new users, the SJ Series blower-type static eliminators allow for easy installation and simple use.

SPOT TYPE

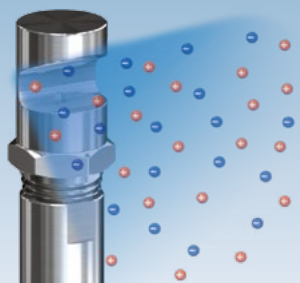

Flat diffusion nozzle



Flat nozzle

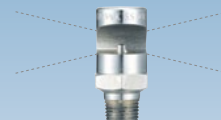

Flat diffusion nozzle

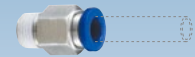

Threaded tube nozzle



Two-way branch threaded tube nozzle

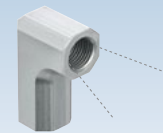

L-type nozzle



Relay adapter (Straight)

Selectable head attachments

The SJ Series spot-type static eliminator provides several head attachments as optional accessories in addition to the small-sized static elimination head, which allows for flexible use where static elimination must be incorporated into a user's equipment. With this variety of head attachments, the spot-type static eliminators enable static elimination of varying configurations in focused areas.

BAR TYPE SJ-H Series

SUITABLE FOR HIGH-SPEED STATIC ELIMINATION IN WIDE AREAS, INCLUDING CLEAN ROOM ENVIRONMENTS

ULTRA-HIGH SPEED, SENSING IONIZER

Highest static elimination capacity in the industry

The I.R.G. (Insert Ring Ground) structure provides the world's-highest static elimination speed

[5 TIMES FASTER THAN CONVENTIONAL MODELS]

The SJ-H Series adopts the I.R.G. structure which incorporates the GND plate essential for ion generation into the ionizer body. This GND plate is externally mounted on conventional models. The I.R.G. structure directs the flow of generated ions toward the target object, instead of toward the GND plate. This structure increases the quantity of ions applied to the target, providing static elimination speed five times faster than conventional models.

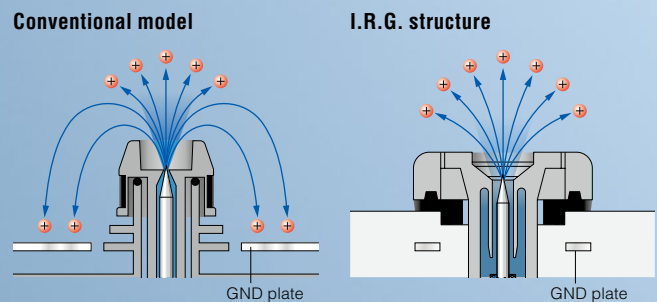

The I.R.G. structure expands the static elimination area (two times larger than that of conventional models)

With the ring-shaped design of the built-in GND plate, the SJ-H Series can radiate a uniform electric field in a ring pattern. Since the ions spread along the electric field, a circular, wide static elimination area can be provided. This feature is effective for applications that require wide area static elimination.

Static elimination area comparison chart

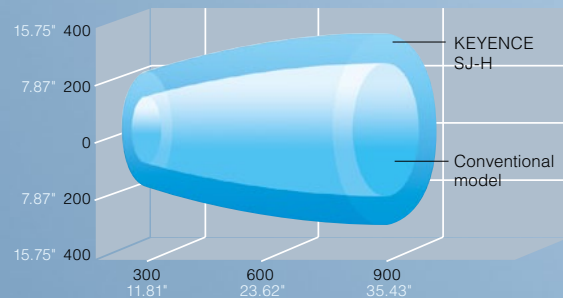

Dual I.C.C. (Dual Ion Current Control) system enables optimum static elimination.

The dual I.C.C. system is further advanced from the conventionally proven I.C.C. system found in other KEYENCE models. The SJ-H Series adopts a dual I.C.C. system that can change the applied voltage in addition to the variable pulse width, thus providing more flexible control of ion generation level per unit time.

This system enables optimum static elimination relative to a change in the ambient environment (temperature, humidity, etc.) and the electrode probe condition.

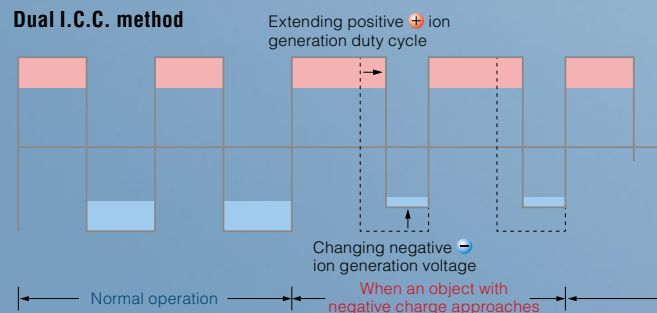



The best maintenance-saving performance in the industry

The sheath air guide structure reduces maintenance downtime

[5 times less maintenance than conventional models]

The supplied air is conveyed through a three-stage port in the probe cap, fully contained within the air chamber. The air contained in the chamber passes through the channel around the probe to generate a laminar flow. The concave structure at the air outlet blocks external disturbance, resulting in an excellent protective effect. This structure can remarkably reduce adhesion of foreign objects on the electrode probe tip. This results in five times less maintenance than conventional models.

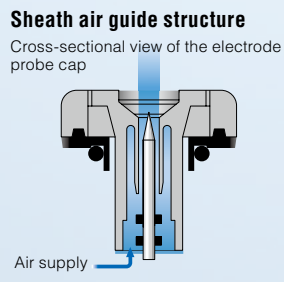

Maintenance indicators

The SJ-H Series includes a self-diagnosis function that monitors the ion generation level. With the bar LED indicators and alarm outputs, the ionizer alerts you of the need for maintenance.



Easy electrode probe replacement

Since the electrode probe is attached with a PIN connector or cassette, users can easily replace the electrode probe.



3-way alarm output

The SJ Series provides the self-diagnosis function that monitors three types of abnormalities. If an abnormality is detected, the LED indicators identify the error condition and an external output is activated. Centralized control of ionizers is enabled by monitoring the external output.

Cleaning warning

Monitors reduction in ion generation level due to dirt or wear of the electrode probe.

Condition warning

Monitors a high charge level that cannot provide a sufficient static elimination effect.

Alarm warning

Monitors abnormal discharge or damage to the ionizer.



Air purge function

The clean air supply function blows air from the area surrounding the electrode probe. This function helps to prevent dust adhesion to the electrode.

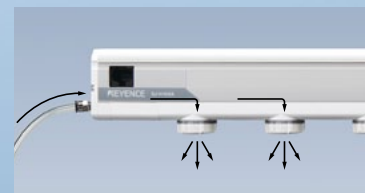

N₂ (nitrogen) purging static elimination

As a standard feature, N₂ purge systems used in semiconductor and liquid crystal manufacturing processes are compatible with the SJ-H Series static eliminators.

The highest static elimination capacity in the industry



LOW-VOLTAGE 24V WIRING

Low-voltage 24V wiring eliminates the adverse effect of discharge on cabling and surrounding equipment, allowing the construction of a highly reliable system.

Double Port Electrode Probe

[DOUBLE PORT ELECTRODE PROBE]

In addition to the sheath air guide structure that minimizes dust adhesion, the double port electrode probe cap is used to ensure high-speed static elimination while maintaining laminar flow.

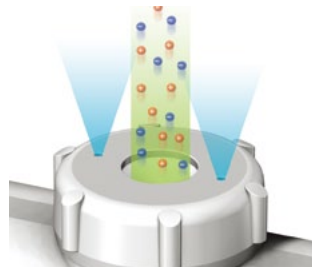

High-density tungsten probe prevents wear

Because of the intergranular density of its tungsten probe, the SJ-H Series can maximize the ion generation level and reduce probe damage during maintenance. Use of the high-density tungsten probe results in an improved static elimination effect and less maintenance.

* Condition: Energized for 2 months, After cleaning with alcohol

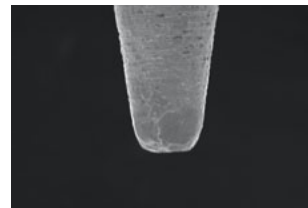

Intergranular density: High

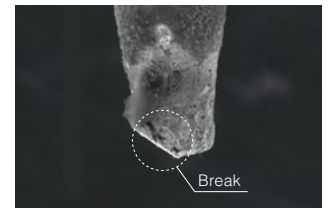

Intergranular density: Low

Static elimination stop function

This function stops the applied voltage, while the main power supply remains ON, ensuring safe operation during maintenance.

Built-in controller

The SJ-H Series incorporates the controller and high-voltage power supply within the unit, enabling a space-saving layout.

SJ-H Models

*Effective length indicates the static elimination range at 50 mm 1.97" operating distance.

Static elimination length (Effective length)		Model
380 mm 14.96" (360 mm 14.17")		SJ-H036A
600 mm 23.62" (600 mm 23.62")		SJ-H060A
840 mm 33.07" (840 mm 33.07")		SJ-H084A
1080 mm 42.52" (1080 mm 42.52")		SJ-H108A
1320 mm 51.97" (1320 mm 51.97")		SJ-H132A
1560 mm 61.42" (1560 mm 61.42")		SJ-H156A
1800 mm 70.87" (1800 mm 70.87")		SJ-H180A
2040 mm 80.32" (2040 mm 80.32")		SJ-H204A
2280 mm 89.76" (2280 mm 89.76")		SJ-H228A
2520 mm 99.21" (2520 mm 99.21")		SJ-H252A
3000 mm 118.11" (3000 mm 118.11")		SJ-H300A

SJ-H Series

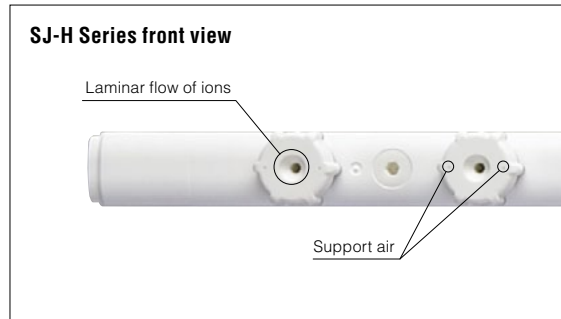

INDICATORS AND OUTPUTS

Safety functions, abnormal discharge detection output, electrostatic charge monitor, and ion level alarm are standard features.

APPLICATIONS

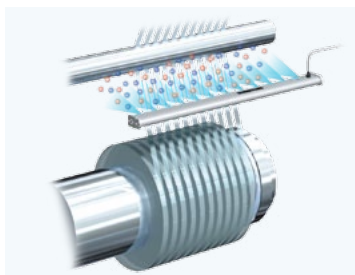

Static elimination of slitters

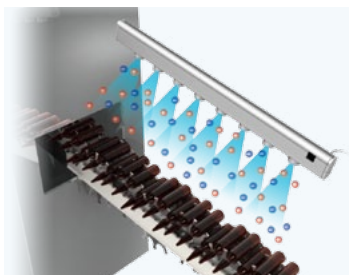

Prevent dust adhesion to ampoules after heat treatment

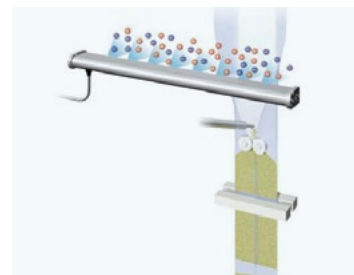

Prevent foreign material adhesion between heat seal layers

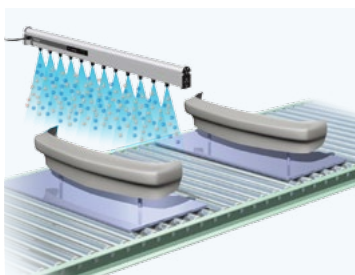

Static elimination in the coating process of bumpers

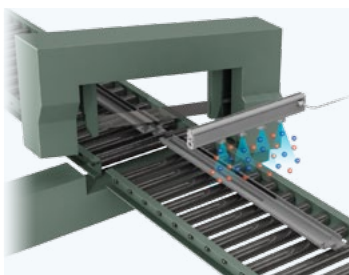

Chip removal during cutting sashes

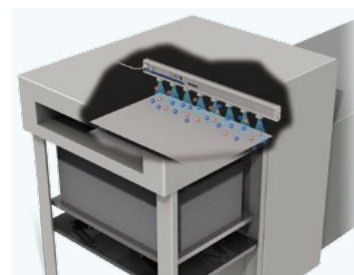

Defect prevention in the offset printing process

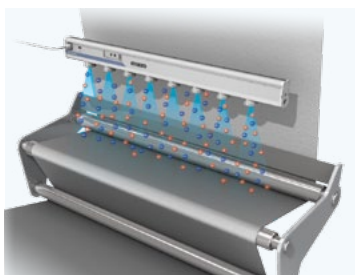

Static elimination of unwoven cloth

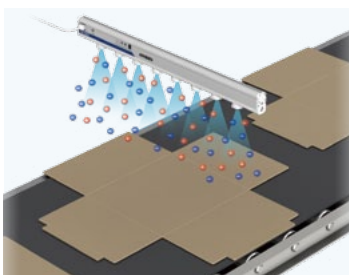

Defect prevention of adhesive painting on cardboard

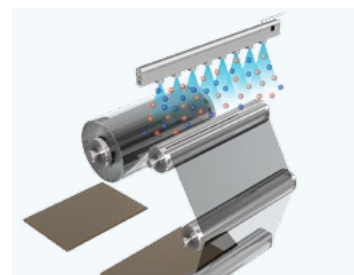

Static elimination when attaching copper plates/films

BLOWER TYPE SJ-F Series

SUITABLE FOR CONTINUOUS STATIC ELIMINATION OVER WIDE AREAS AT LONG DISTANCES

WIDE-AREA SENSING IONIZER

Reduce electrostatic problems by eliminating static in the entire environment, including manufactured goods and surrounding components.

Highest Static Elimination Speed in its class

300 mm (11.81") type
SJ-F2500



STATIC ELIMINATION AREA

2× LARGER
than conventional models

STATIC ELIMINATION SPEED

2× FASTER
than conventional models



FULL SPECTRUM
High-precision Ion Balance

±5V

Ion balance area diagram (Typical)

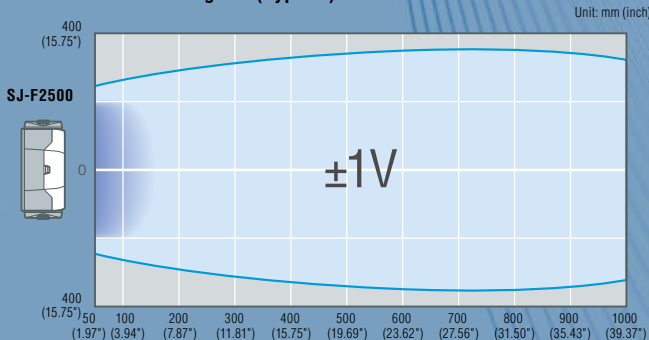

Conventional
static elimination area



Highest static elimination speed in its class

By combining the reputable pulse AC method and I.C.C control, the SJ-F Series has achieved the best ion production per electrode in its class. In addition, by inserting a high-power fan into the louver structure, the SJ-F Series has also achieved the fastest wide-area static elimination in its class.

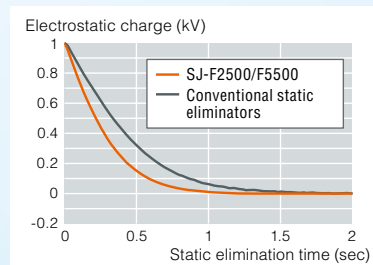

High-precision ion balance of the entire area

The SJ-F Series has adopted the pulse AC method that applies alternating high voltage to the electrode probe, producing ions of both polarities. By improving the close-range ion balance that is an issue with conventional methods, high-precision ion balance has been achieved over the entire area.

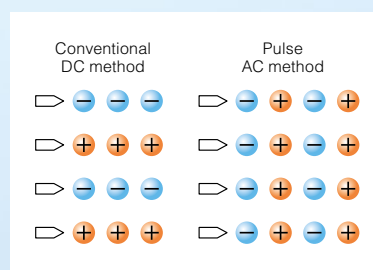

Wide-range air volume adjustment

With a compact, large air volume fan and independent PWM control, wide-range adjustments become possible from ultra-low air volumes all the way to large air volumes. Any application is possible, including applying film where close range, moderate air volume is necessary, or where long-distance, high-speed static elimination is required.

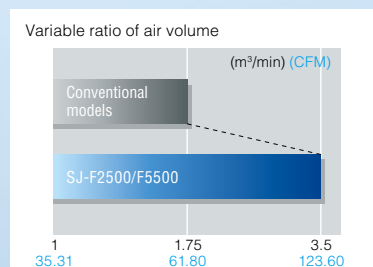

Sensing ionizer

Auto-sensing and feedback functions of the I.C.C. control method are pre-installed in the device. By supplying ions at the optimal balance to the electrostatic charge, complicated initial settings and maintenance become obsolete, thus allowing increasingly effective static elimination.

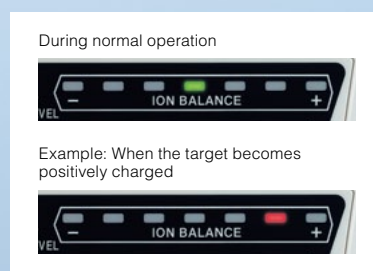

600 mm (23.62") type
SJ-F5500

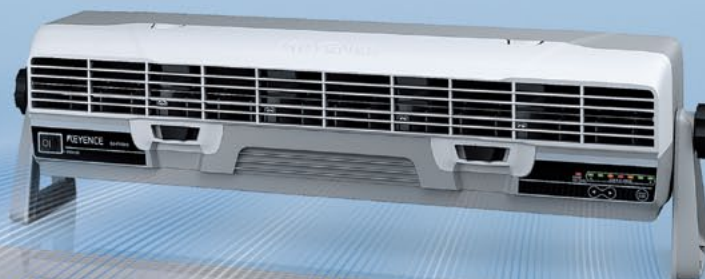

SJ-F Series

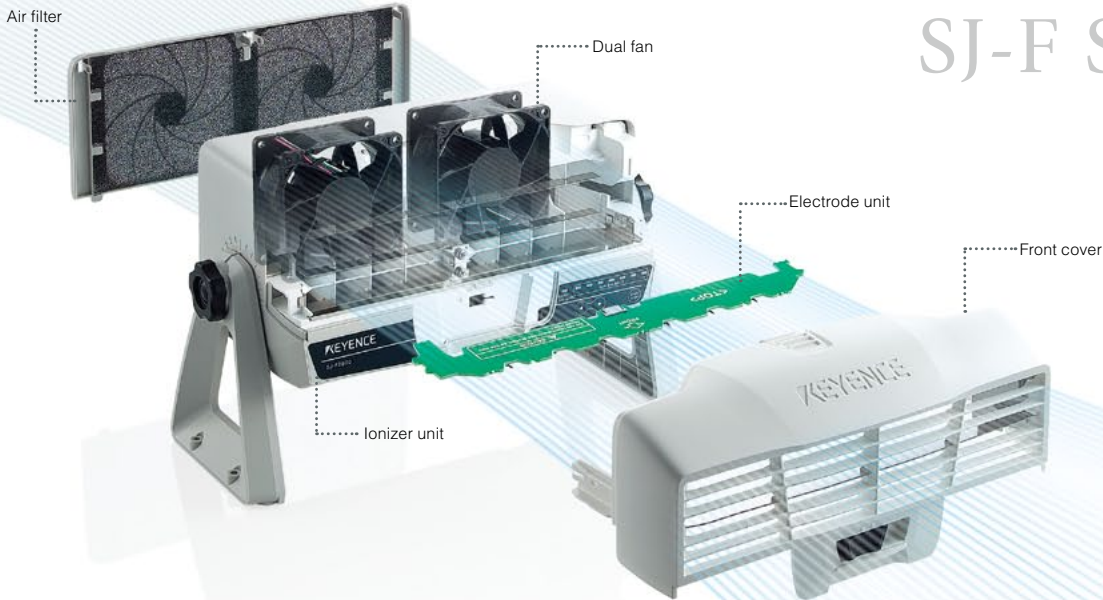

Low maintenance with continuous high static elimination ability

Low maintenance

By incorporating KEYENCE's unique I.C.C. control method, the degradation of static elimination resulting from wear or buildup on the probes is reduced, saving on maintenance costs; up to 3 times compared to conventional models.

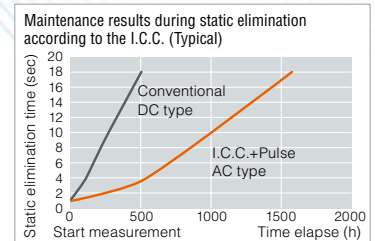
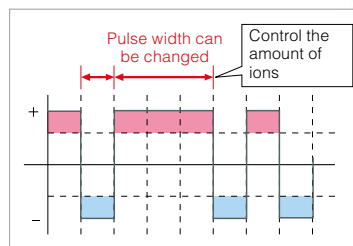

Straightforward maintenance structure*

The front cover connected to the electrode unit can be removed with one hand. Cleaning of the electrode probes is also quick and easy. Furthermore, no tools are required to exchange the electrode unit, allowing a safe and rapid changeover.

*SJ-F2000 Series



Compact installation

A compact body has become a reality by adopting specially designed louvers. While being a space-saving, compact device, the SJ-F Series is still capable of a wide static elimination range.

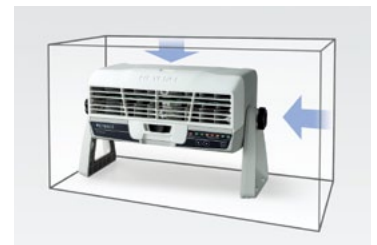

Arm-mounting option

KEYENCE has prepared a specialized mounting bracket that directly attaches to "VESA standard" mounting arms, such as those used for liquid crystal displays. By mounting the device using a workbench pole, the static eliminator can be used in limited spaces.

(SJ-F2000 Series : OP-87149, SJ-F5000 Series : OP-87150)



APPLICATIONS

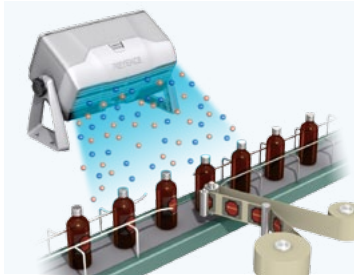

Static elimination of labelers

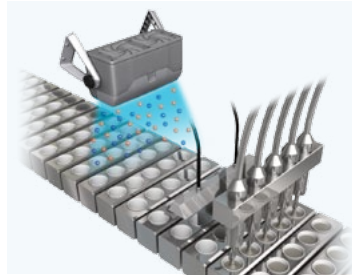

Prevent adhesion of foreign materials during food/medical/ pharmaceutical filling applications



Prevent pellets from sticking to a hopper's internal surface

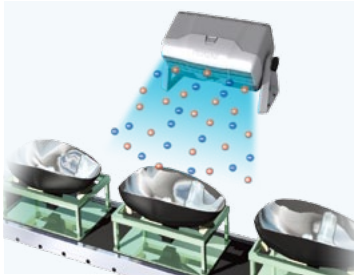

Static elimination of headlights



Static elimination during shipping inspections

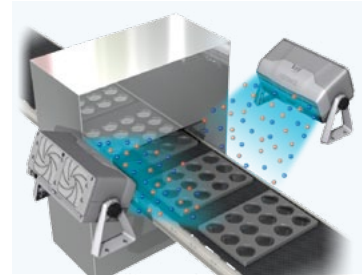

Static elimination of lenses after cleaning

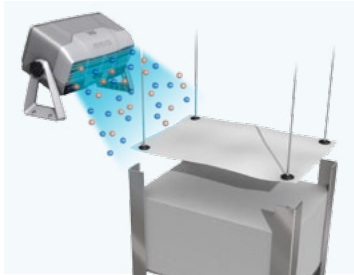

Prevent double feeding of workpieces

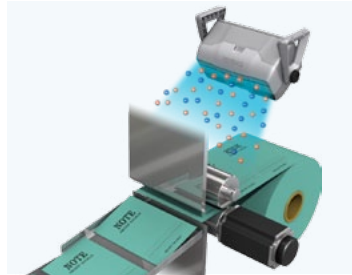

Prevent workpieces from sticking to the cutting machine during the cutting process

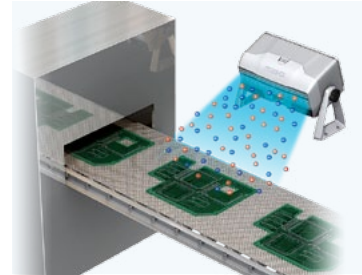

Static elimination of substrates after burning

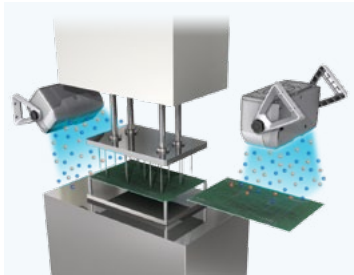

Static elimination of in-circuit testers

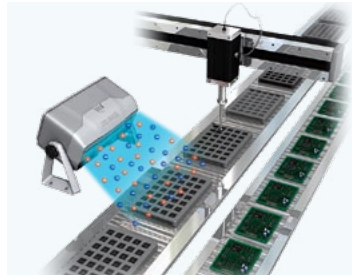

Static elimination on chip and PCB products



Prevention of electrostatic discharge failures in the testing process of semiconductors

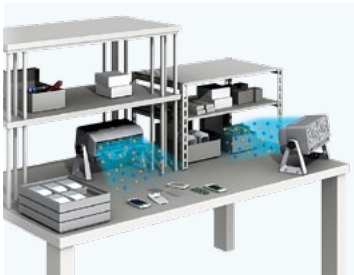

Static elimination during electronics production processes



Static elimination of automotive doors before coating

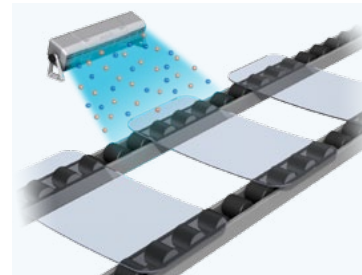

Static elimination of windshields after cleaning

SPOT TYPE SJ-M Series

SUITABLE FOR PINPOINT, HIGH-PRESSURE AIR PURGING STATIC ELIMINATION

ULTRA-SMALL, INTEGRATED SENSING IONIZER

HIGH-PERFORMANCE
MICRO IONIZER HEADS
ULTRA-FINE NOZZLE

Standard probe type
SJ-M021

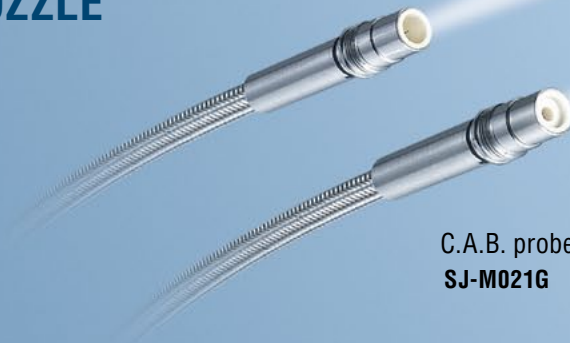

C.A.B. probe type
SJ-M021G

HIGH-PERFORMANCE
MICRO IONIZER HEADS
ULTRA-SMALL BAR



7 probe bar type
SJ-M071G/M071C

3 probe bar type
SJ-M031G/M031C









HIGH-PERFORMANCE
MICRO STATIC ELIMINATOR
CONTROLLER



Controller
SJ-M201/M301



OPTIONS FOR A FLEXIBLE DESIGN

SELECTABLE NOZZLES	ADAPTER (STRAIGHT)	ADAPTER (L-TYPE)	APPLICATION
Flat nozzle 	SJ-MS1 	SJ-ML1 	Suitable for wide-angle, wide-area static elimination
Flat diffusion nozzle 	SJ-MS2 	SJ-ML2 	Suitable for wide-angle, wide-area static elimination by changing the angle and direction
Threaded tube nozzle 	SJ-MS3 	SJ-ML3 	Suitable for pin-point static elimination in limited space
Two-way branch threaded tube nozzle 	SJ-MS4 	SJ-ML4 	Suitable for pin-point static elimination over multiple locations
L-type nozzle 		SJ-ML 	Suitable for static elimination by changing static elimination angle and direction

High-precision ion balance control: I.C.C. method

The I.C.C. method conducts high-precision sensing of electrostatic charges on the target object and automatically controls ion generation quantities for the optimum level.

Comparison of ion balance

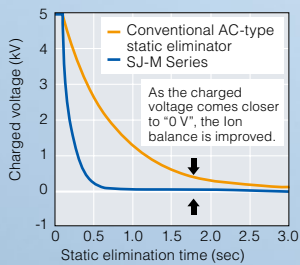

Conceptual image of the I.C.C. method

When an object with a positive charge approaches:



When an object with a negative charge approaches:



The heat-resistant design allows for use in high temperature environments

The SJ-M Series provides heat resistance of up to 80°C (176°F), enabling use for applications in high-temperature environments.

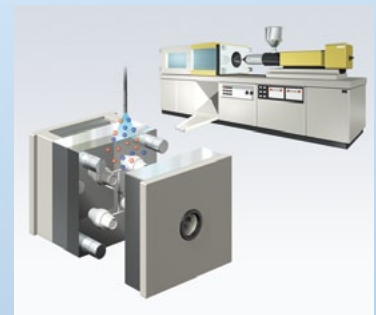

Static elimination in the die of a molding machine

Silicon probe bar type : SJ-M031C/M071C

Silicon probes are suitable for environments in which metal contamination must be avoided.



Silicon probe

Ultra-small static elimination head has no limitation on installation space.

Since the SJ-M Series provides a direct static elimination structure that locates the ion generation point at the tip of the head, it enables high-speed and high-precision static elimination, where it is needed most.

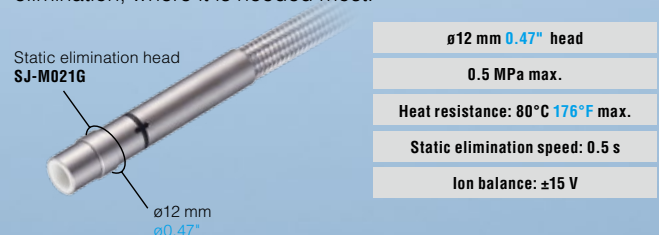

Highly-functional controller with built-in static elimination indicators

SJ-M201/M301

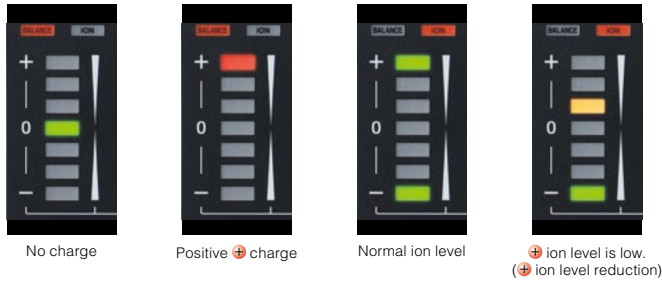

Electrostatic charge monitor

The SJ-M Series is equipped with an electrostatic charge monitor that allows the quantity and polarity of electrostatic charges on a target to be easily monitored at a glance.

Ion level monitor

The ion level monitor performs self-diagnosis of the ion emission quantity and displays the ion balance with the bar LEDs. Also, it activates the alarm output when the ion emission quantity falls below a specific level. This function allows you to monitor dust adhesion to the electrode probe.

Condition monitor

When the electrostatic charge level is extremely high, or when there is insufficient static elimination, the condition monitor activates the LED indicator and outputs an alarm signal to external equipment.

Safe operation

Low-voltage 24 V wiring

Using 24 V low-voltage wiring, the SJ-M Series prevents cable deterioration caused by electrostatic discharge and eliminates the influence on surrounding equipment. Because of this, the SJ-M Series maintains a highly reliable system configuration.

Abnormal discharge detection circuit

When abnormal electrostatic discharge is detected, the SJ-M Series outputs an alarm signal and simultaneously turns off the high-voltage power supply to prevent potential problems.

Static elimination stop input

With the static elimination stop input, the SJ-M Series can stop applying voltage to the electrode while the main power supply remains active, ensuring safe operation during maintenance.

Compliance with CE Marking

The SJ-M Series static eliminator ensures a high safety level in compliance with the requirements of the CE Marking standard.

APPLICATIONS

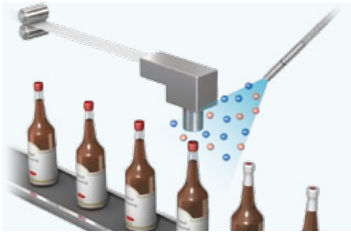

Prevent contamination in shrink packaging



Static elimination in capping applications

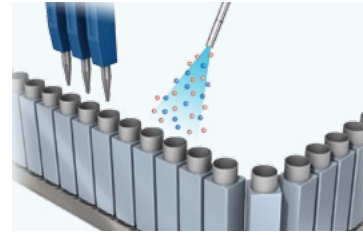

Static elimination of tubes in filling processes

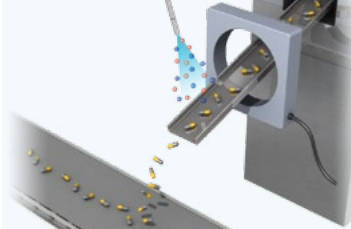

Static elimination of tablets after the forming process



Static elimination of containers before inkjet printing

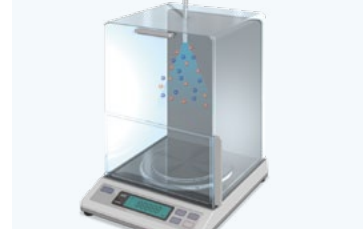

Prevent differences in measurement values of an electronic balance

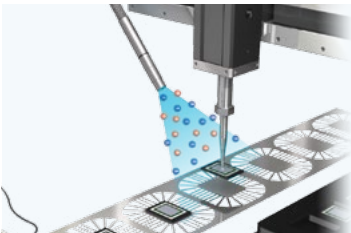

Prevent electrostatic discharge failures on bonding machines

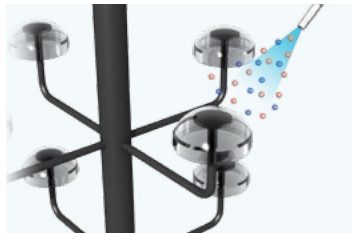

Static elimination during shot blasting

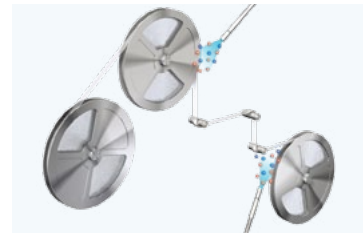

Static elimination of chips on embossed reels

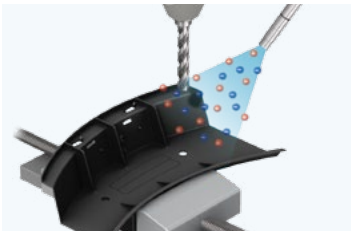

Prevent swarf adhesion to resin parts

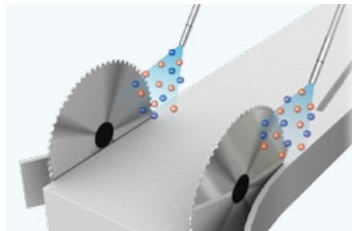

Static elimination in the slitting process

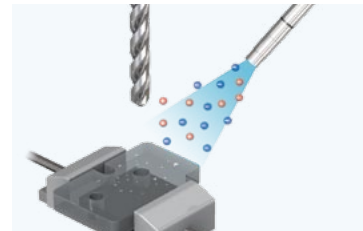

Prevent film adhesion in the cutting process

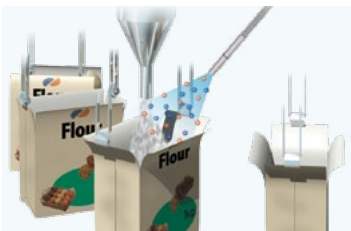

Prevent clogged nozzles in the filling process of powders

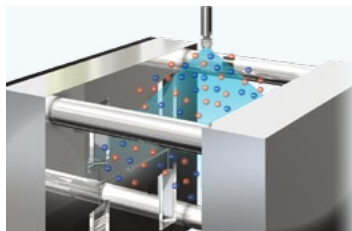

Static elimination of metal molds

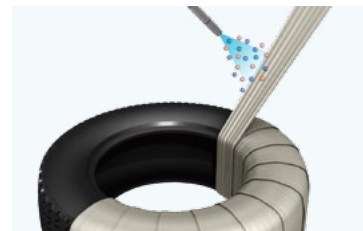

Prevent separation discharge in tire packaging

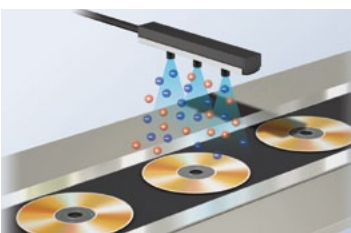

Static elimination of Digital Video Discs

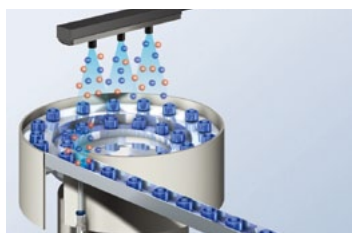

Removing static electricity in a part feeder

SPECIFICATIONS

Model	SJ-H036A	SJ-H060A	SJ-H084A	SJ-H108A	SJ-H132A	SJ-H156A	SJ-H180A	SJ-H204A	SJ-H228A	SJ-H252A	SJ-H300A
Ion generation method	Corona discharge method										
Structure	Shock-proof, resistance-coupled type										
Voltage application method/applied voltage	Pulse AC method/±7000 V										
Ion balance control method	Dual I.C.C. method										
Ion balance ¹	±30 V										
Operating distance	50 to 2000 mm 1.97" to 78.74"										
Control input	NPN open collector or non-voltage contact signal										
Control output	NPN type photo-relay, 100 mA max. (40 V max.)										
Ratings	Power supply voltage	24 VDC-36 V±10%									
	Current consumption	500 mA (at 24 VDC)/350 mA (at 36 VDC)									
	Overvoltage category	I									
	Pollution degree	2									
Primary features	Condition alarm, ion level alarm, alarm output										
Air purge connection port	Rc 1/8										
Air purge air supply pressure	0.5 MPa or less										
Materials	Electrode probe	Tungsten									
	Body	ABS resin/PC									
Environmental resistance	Ambient temperature	0 to +40°C 32 to +104°F									
	Relative humidity	35 to 85%RH (No condensation)									
Effective length ²	360 mm 14.17"	600 mm 23.62"	840 mm 33.07"	1080 mm 42.52"	1320 mm 51.97"	1560 mm 61.42"	1800 mm 70.87"	2040 mm 80.32"	2280 mm 89.76"	2520 mm 99.21"	3000 mm 118.11"
Total length (A) ³	380 mm 14.96"	620 mm 24.41"	860 mm 33.86"	1100 mm 43.31"	1340 mm 52.76"	1580 mm 62.21"	1820 mm 71.66"	2060 mm 81.11"	2300 mm 90.56"	2540 mm 100.01"	3020 mm 118.91"
Weight	Controller	150 g	—	—	—	—	—	—	—	—	—
	Static elimination bar	500 g	780 g	980 g	1200 g	1400 g	1550 g	1750 g	2000 g	2350 g	3150 g

1. The value is measured under the following condition.

Operating distance	300 mm 11.81" (22 Hz)	600 mm 23.62" (10 Hz)	1500 mm 59.06" (1 Hz)
Operating ambient temperature	0 to +40°C 32 to +104°F		
Operating ambient humidity	35 to 65%RH		

0.3 m/s 0.98 ft/s downflow

2. The effective length is determined based on the static elimination range at a distance of 50 mm 1.97".

3. The total length includes the end units.

CHARACTERISTICS

Static elimination range vs. static elimination time (33 Hz)

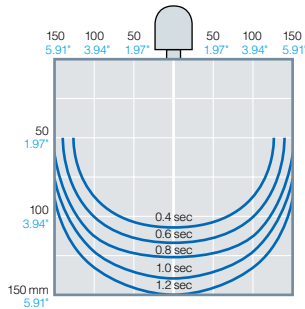

Measurement conditions:

Static elimination time from ±1000 V to ±100 V
Using a 150 × 150 mm 5.91" × 5.91" plate monitor (20 pF).
Model: SJ-H108A, No downflow

Static elimination range vs. static elimination time (10 Hz)

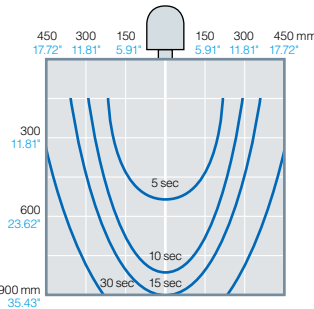

Measurement conditions:

Static elimination time from ±1000 V to ±100 V
Using 150 × 150 mm 5.91" × 5.91" plate monitor (20 pF).
Model: SJ-H108A, under a 0.3 m/s 0.98 ft/s downflow

Static elimination range vs. static elimination time (1 Hz)

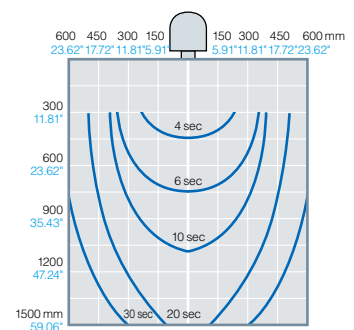

Measurement conditions:

Static elimination time from ±1000 V to ±100 V
Using 150 × 150 mm 5.91" × 5.91" plate monitor (20 pF).
Model: SJ-H108A, under a 0.3 m/s 0.98 ft/s downflow

Relationship between air pressure and air volume according to static elimination bar length (with air supply at both sides)

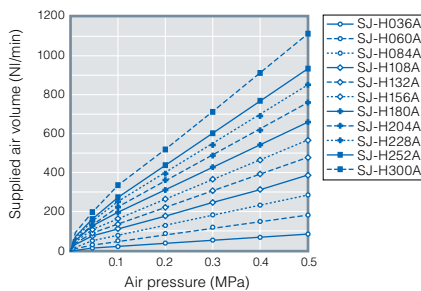

Relationship between static elimination speed and operating distance according to air pressure

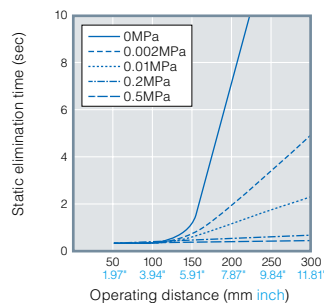

Measurement conditions:

Static elimination time from ±1000 V to ±100 V
Using 150 × 150 mm 5.91" × 5.91" plate monitor (20 pF).
Model: SJ-H108A, No downflow

Static elimination range vs. static elimination time (Maximum air supply)

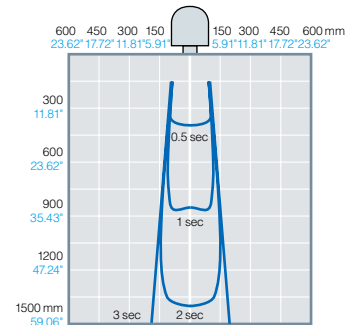

Measurement conditions:

Static elimination time from ±1000 V to ±100 V
Using 150 × 150 mm 5.91" × 5.91" plate monitor (20 pF).
Model: SJ-H108A, No downflow

Table of dimensions by model

Unit: mm inch

Model	SJ-H036A	SJ-H060A	SJ-H084A	SJ-H108A	SJ-H132A	SJ-H156A	SJ-H180A	SJ-H204A	SJ-H228A	SJ-H252A	SJ-H300A
A Total length	380 14.96"	600 23.62"	840 33.07"	1080 42.52"	1320 51.97"	1560 61.42"	1800 70.87"	2040 80.32"	2280 89.76"	2520 99.21"	3000 118.11"
B Static elimination bar length	340 13.39"	560 22.05"	800 31.5"	1040 40.94"	1280 50.39"	1520 59.84"	1760 69.29"	2000 78.74"	2240 88.19"	2480 97.64"	2960 116.54"
C Mounting pitch	365 14.37"	585 23.03"	825 32.48"	1065 41.93"	1305 51.38"	1545 60.83"	1785 70.28"	2025 79.72"	2265 89.17"	2505 98.62"	2985 117.52"
D Electrode pitch and length	P60 x 3=180 P2.36"x3=7.09"	P60 x 7=420 P2.36"x7=16.54"	P60 x 11=660 P2.36"x11=25.98"	P60 x 15=900 P2.36"x15=35.43"	P60 x 19=1140 P2.36"x19=44.88"	P60 x 23=1380 P2.36"x23=54.33"	P60 x 27=1620 P2.36"x27=63.78"	P60 x 31=1860 P2.36"x31=73.23"	P60 x 35=2100 P2.36"x35=82.68"	P60 x 39=2340 P2.36"x39=92.13"	P60 x 47=2820 P2.36"x47=111.02"

DIMENSIONS

Unit: mm inch

When the end units are attached

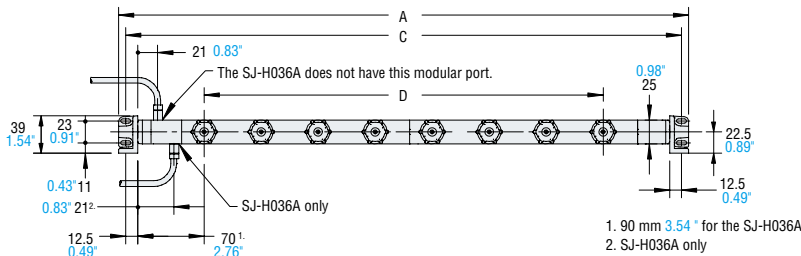
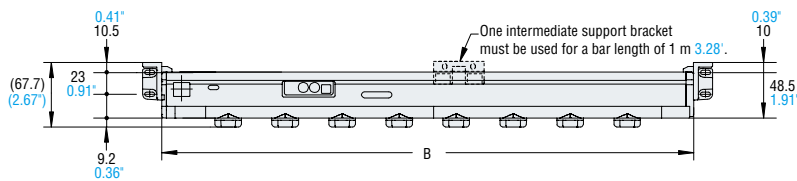

- 1. 90 mm 3.54" for the SJ-H036A
- 2. SJ-H036A only

Left side of the bar

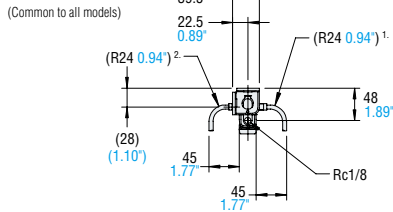

- 1. The SJ-H036A does not have this modular part.
- 2. SJ-H036A only

Right side of the bar

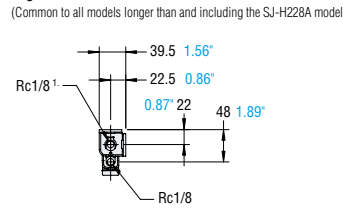

- 1. Not provided for the SJ-H204A or shorter models.

SJ-H036A (Controller)

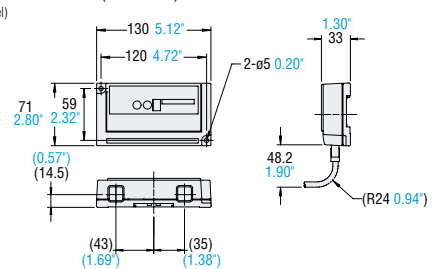

End unit (OP-84301)

End unit L

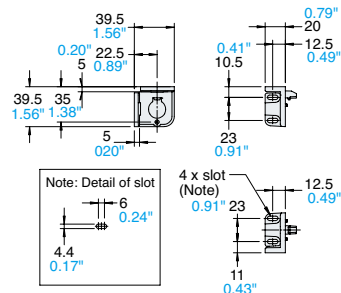

End unit R

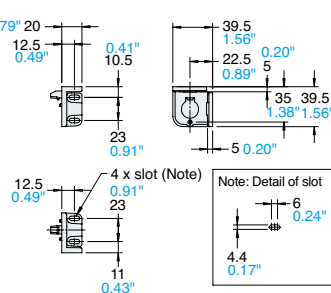

Intermediate support bracket (OP-84300)

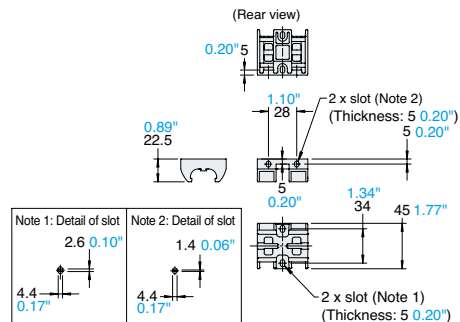

When a rotating mounting bracket is attached

Unit: mm inch

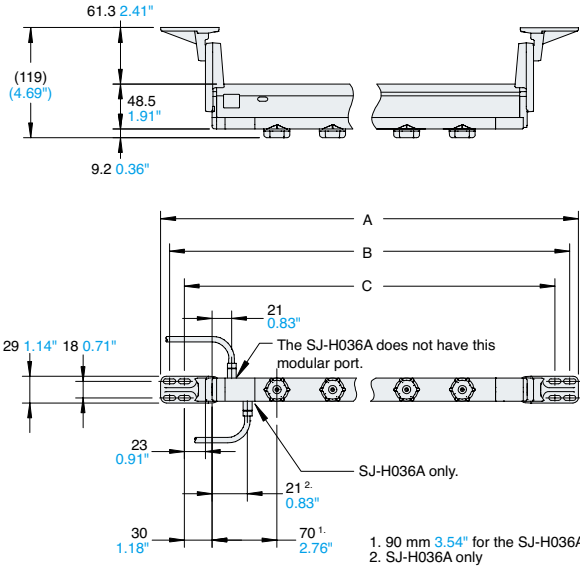

	Total length (A)	Mounting pitch (B)	Mounting pitch (C)
SJ-H036A	451 17.76"	432 17.01"	400 15.75"
SJ-H060A	671 26.42"	652 25.67"	620 24.41"
SJ-H084A	911 35.87"	892 35.12"	860 33.86"
SJ-H108A	1151 45.31"	1132 44.57"	1100 43.31"
SJ-H132A	1391 54.76"	1372 54.02"	1340 52.76"
SJ-H156A	1631 64.21"	1612 63.46"	1580 62.20"
SJ-H180A	1871 73.66"	1852 72.91"	1820 71.65"
SJ-H204A	2111 83.11"	2092 82.36"	2060 81.10"
SJ-H228A	2351 92.56"	2332 91.81"	2300 90.55"
SJ-H252A	2591 102.01"	2572 101.26"	2540 100.00"
SJ-H300A	3071 120.91"	3052 120.16"	3020 118.90"

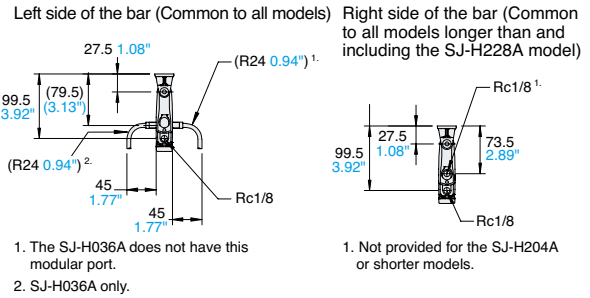

Rotating mounting bracket (side) OP-84297

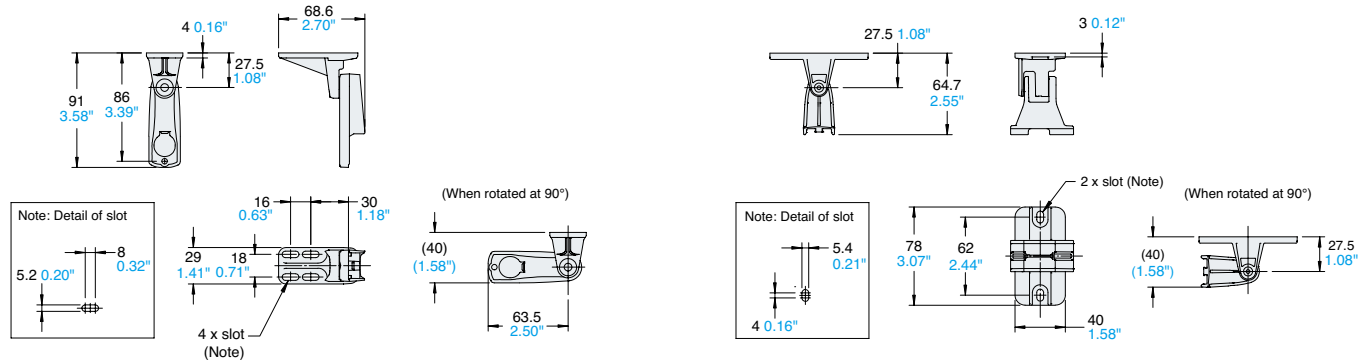

OPTIONS

<p>SJ-C2U/C5U/C10U</p> <p>10-pin I/O cable (2 m 6.56', 5 m 16.40', 10 m 32.81')</p>	<p>OP-42210/OP-42211/ OP-42212</p> <p>10-pin/10-pin cable (For OP-84296) (2 m 6.56', 5 m 16.40', 10 m 32.81')</p>	<p>SJ-C2H/C5H/C10H</p> <p>10-pin/10-pin cable (for SJ-H036A) (2 m 6.56', 5 m 16.40', 10 m 32.81')</p>	<p>OP-84454</p> <p>Electrode port cleaning kit 2 for SJ-H Series</p>	<p>OP-84455</p> <p>Replacement filter for electrode cleaning kit 2 (10 pieces)</p>	<p>OP-84299</p> <p>Electrode tip cleaning kit for SJ-H Series</p>	<p>OP-42218</p> <p>Replacement filter for electrode cleaning kit (10 pieces)</p>
<p>OP-84363 (Spare)</p> <p>Electrode probe replacement kit for SJ-H Series</p>	<p>OP-84293</p> <p>Tungsten electrode probe for SJ-HA (4 pieces)</p>	<p>OP-84296</p> <p>Junction relay box for SJ-H Series</p>	<p>OP-84300 (Spare)</p> <p>Intermediate support bracket for SJ-H Series</p>	<p>OP-84301 (Spare)</p> <p>End unit for SJ-H Series</p>	<p>OP-84297</p> <p>Rotating mounting bracket pair (right and left sides)</p>	<p>OP-84298</p> <p>Rotating mounting bracket (intermediate)</p>

Main unit

Type	300 mm 11.81" type	600 mm 23.62" type	300 mm 11.81" type	600 mm 23.62" type	300 mm 11.81" type	600 mm 23.62" type
Model	SJ-F2500	SJ-F5500	SJ-F2000	SJ-F5000	SJ-F2010	SJ-F5010
Voltage application method	Pulse AC method					
Applied voltage	±7000V					
Ion balance control method	I.C.C.					
Ion balance ¹	±5V					
Static elimination time ²	Approx. 0.6 sec			Approx. 1.0 sec		
Operating distance	50 mm 1.97" min.					
Maximum wind speed ¹	5.7 m/s 18.70 ft/s			3.5 m/s 11.48 ft/s		
Maximum air volume	4.0 m ³ /min 141.26 CFM	10.0 m ³ /min 353.15 CFM	2.5 m ³ /min 88.29 CFM	6.2 m ³ /min 218.95 CFM	2.5 m ³ /min 88.29 CFM	6.2 m ³ /min 218.95 CFM
Ozone density	0.005 ppm max.					
Control input	Static elimination interruption input					
Control output	Alarm/ Ion level alert/ Condition alert	NPN open-collector	—	—	24 VDC input 100 mA (40 V max.) (Residual voltage 1 V or less)	
		PNP open-collector	—	—	100 mA (24 V ±10%) (Residual voltage 3 V or less)	
Rating	Power supply voltage	24VDC±10%	100 to 240VAC (50/60Hz)	24VDC±10%	100 to 240VAC (50/60Hz)	24VDC±10%
	Current consumption	1.2 A	90 VA	0.9 A	65 VA	1.9 A
Environment resistance	Operating ambient temperature	0 to +50°C 32 to +122°F				
	Operating relative humidity	35 to 65%				
	Overvoltage category	II				
	Pollution degree	2				
Power source input type	KEYENCE AC adapter or DC option	AC cord input	KEYENCE AC adapter or DC option	AC cord input	Terminal block DC input	
Weight	Approx. 2 kg	Approx. 5 kg	Approx. 2 kg	Approx. 5 kg	Approx. 2 kg	Approx. 4 kg

1. Measured at a distance of 300 mm 11.81" from the front of the fan

2. Measured at a distance of 300 mm 11.81" from the front of the fan and at maximum air volume

CHARACTERISTICS

Static elimination range and time (Typical)

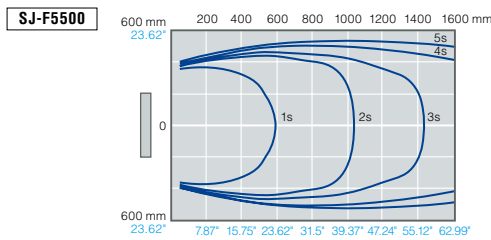
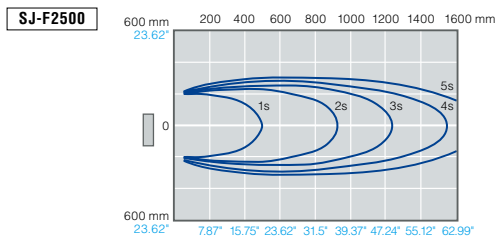

[Measuring conditions]

Time required for static elimination from ±1000 V to ±100 V (Air volume: MAX)

Plate monitor:
150 mm × 150 mm
5.91" × 5.91"
(20pF)

Static elimination speed (Typical)

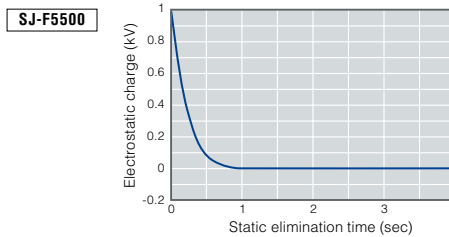
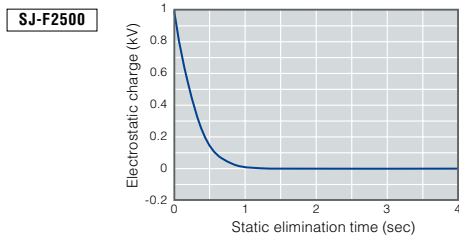

[Measuring conditions]

Time required for static elimination from ±1000 V to ±100 V (Air volume: MAX)

Operating distance: 300 mm 11.81"
Plate monitor:
150 mm × 150 mm
5.91" × 5.91"
(20pF)

Static elimination range and time (Typical)

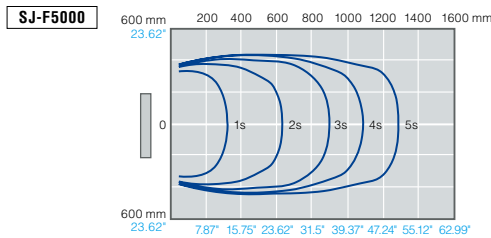
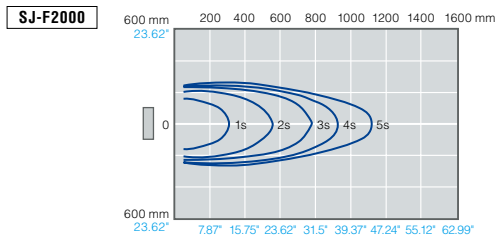

[Measuring conditions]

Time required for static elimination from ±1000 V to ±100 V (Air volume: MAX)

Plate monitor:
150 mm × 150 mm
5.91" × 5.91"
(20pF)

Static elimination speed (Typical)

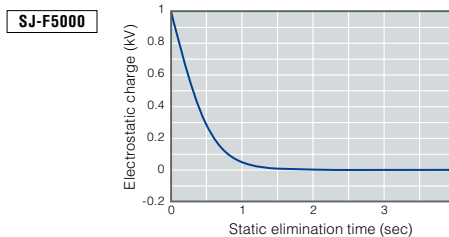
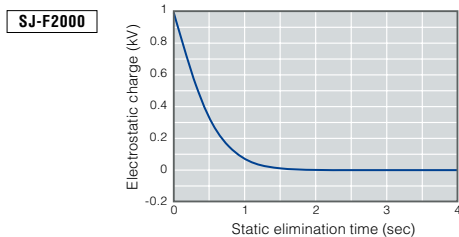

[Measuring conditions]

Time required for static elimination from ±1000 V to ±100 V (Air volume: MAX)

Operating distance: 300 mm 11.81"
Plate monitor:
150 mm × 150 mm
5.91" × 5.91"
(20pF)

SJ-F Series

DIMENSIONS

Unit: mm inch

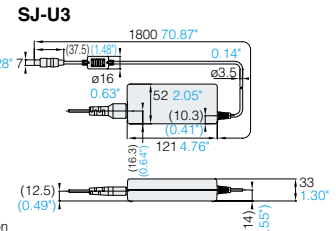
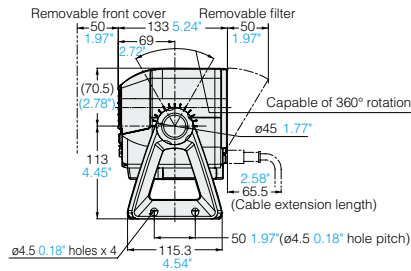
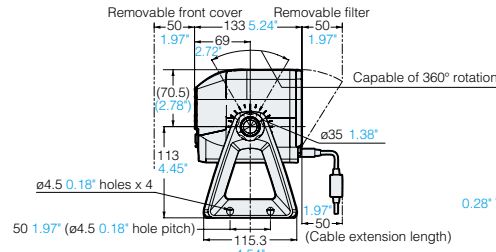
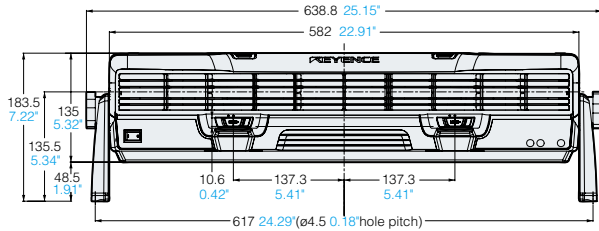
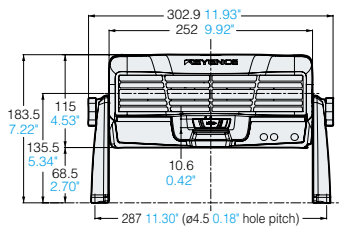

OP-87147

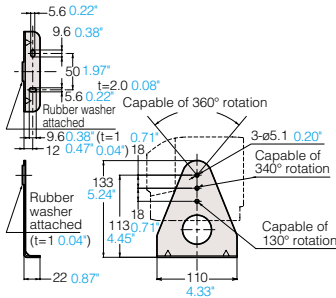

OP-87148

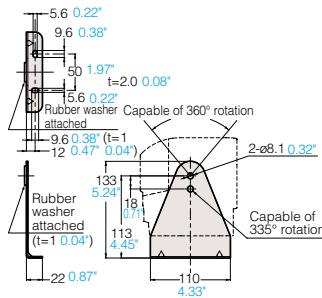

OP-87149

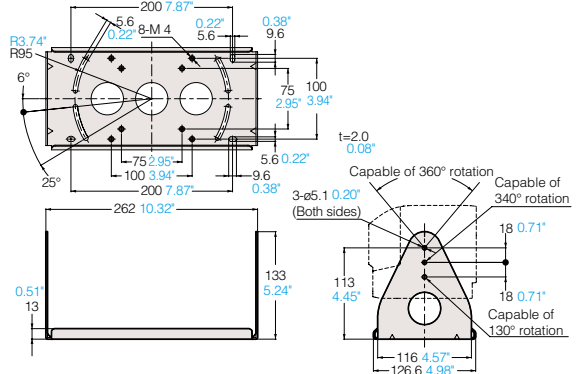

OP-87150

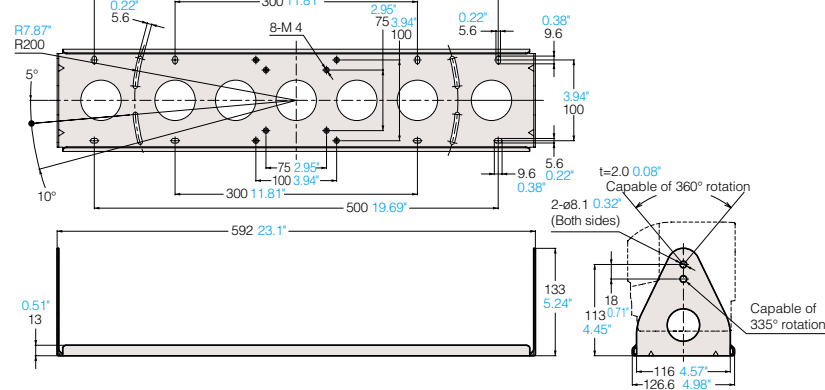

AC adapter

Type		SJ-U3
Rating	Rated input	100 to 240 VAC (50/60Hz)
	Rated output	24VDC 2.7A
Environmental resistance	Operating ambient temperature	0 to +35°C 32 to +95°F
	Operating relative humidity	20 to 80% (No condensation)
Weight	Approx. 260g	

OPTIONS

OP-87153

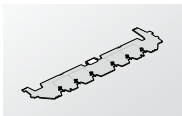

Replacement electrode unit for SJ-F2000 Series

OP-87154

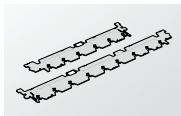

Replacement electrode unit for SJ-F5000 Series

SJ-U3



AC adapter for SJ-F2500/F2000 Series*

OP-87147



L-shaped mounting bracket for SJ-F2000 Series

OP-87148



L-shaped mounting bracket for SJ-F5000 Series

OP-87149



U-shaped mounting bracket for SJ-F2000 Series

OP-87150



U-shaped mounting bracket for SJ-F5000 Series

OP-87151



Rubber stoppers for SJ-F2000/F5000 Series

OP-87152



DC input cable for SJ-F2500/F2000 Series

* For details on the AC cable, contact your local KEYENCE sales office.

SPECIFICATIONS

Model	Controller		SJ-M201	
	Head		SJ-M021/M021G	
Voltage application method			Pulse AC method	
Applied voltage			±5.5 kV	
Rated output voltage			±6 kV	
Ion balance control method			I.C.C. method	
Static elimination time			0.5 sec. max. *1	
Ion balance			±15 V *2	
Supply pressure range			0.001 to 0.5 MPa *3	
Control input			Static elimination stop input	
Control output	Static elimination stop input		Non-voltage input	
	Alarm		NPN open-collector, 100 mA max. (40 V max.)	
	Ion level alert			
	Condition alert			
Condition alert				
Ratings	Power supply voltage		24 VDC ±10%	
	Current consumption		450 mA max.	
Environmental resistance	Operating ambient temperature (Head)		0 to +80°C 32 to +176°F *4,*5	
	Operating ambient temperature (Controller)		0 to +40°C 32 to +104°F	
	Operating relative humidity		35 to 65%RH (No condensation) *3	
Weight	Head		Approx. 600 g	
	Controller		Approx. 300 g	

*1. Operating distance: 50 mm 1.97", Air volume: 60 NL/min, (Ambient temperature: 20 to 30°C 68 to 86°F, Ambient humidity: 40 to 60%RH)

*2. Operating distance: 50 mm 1.97", Air volume: 20 NL/min, (Ambient temperature: 20 to 30°C 68 to 86°F, Ambient humidity: 40 to 60%RH)

*3. For derating of humidity and pressure during use at an ambient temperature higher than 35°C 95°F, contact KEYENCE. For air supply, use clean dry air with -20°C -4°F or lower dew point. The minimum air volume varies depending on the nozzle type. Contact KEYENCE for more information.

*4. The supplied air temperature should be 40°C 104°F or less.

*5. For high-pressure cable only. For other parts, operating ambient temperature is 0 to +40°C 32 to +104°F.

Model	Controller		SJ-M301	
	Head		SJ-M031G/M031C SJ-M071G/M071C	
Voltage application method			Pulse AC method	
Applied voltage			±5.5 kV	
Rated output voltage			±6 kV	
Ion balance control method			I.C.C. method	
Ion balance *1			±30 V	
Air purge supply pressure			0.2 MPa max.	
Control input	Static elimination stop input		Non-voltage input	
	Alarm		NPN open-collector, 100 mA max. (40 V max.)	
Control output	Ion level alert			
	Condition alert			
Ratings	Power supply voltage		24 VDC ±10%	
	Current consumption		450 mA max.	
Environmental resistance	Operating ambient temperature		0 to +40°C 32 to +104°F	
	Operating relative humidity		35 to 65%RH (No condensation)	
Effective length *2	164 mm 6.46"		324 mm 12.76"	
	220 mm 8.66"		380 mm 14.96"	
Overall length *3	164 mm 6.46"		324 mm 12.76"	
	220 mm 8.66"		380 mm 14.96"	
Weight	Head		Approx. 600 g	
	Controller		Approx. 300 g	

*1. Measured under the following conditions:

Head type	SJ-M031G/M071G	SJ-M031C/M071C
Air purge	3 NL/min per electrode	None
Down flow	0.3 m/s 0.98 ft/s	
Operating distance	50 mm 1.97" (50 Hz), 600 mm 23.62" (8 Hz), 1500 mm 59.06" (1 Hz)	

*2. Effective length indicates static elimination range at 50 mm 1.97" operating distance.

*3. Overall length includes mounting brackets.

CHARACTERISTICS

[Measuring Conditions] Applied voltage: 1000 V, Plate monitor: 150 mm × 150 mm 5.91" × 5.91" (20pF), Installation distance: 300 mm 11.81"

Static elimination range and time (Typical)

SJ-M021G (Applied pressure of 0.5 MPa)

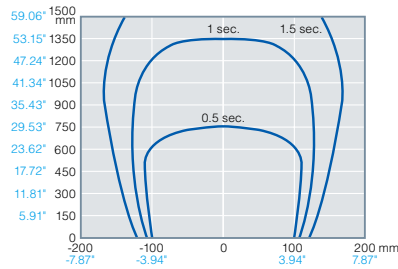

SJ-M021 (Applied pressure of 0.5 MPa)

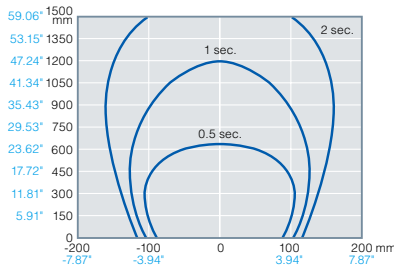

SJ-M031G

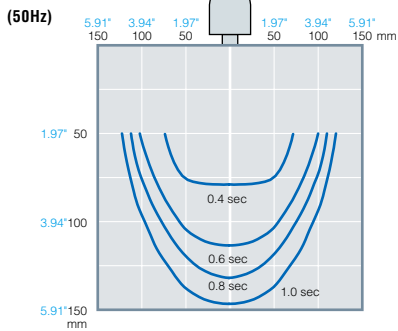

Measurement condition: Static elimination time from ±3,000 V to ±300 V. Using 150 mm × 150 mm 5.91" × 5.91" plate monitor (20 pF) Using SJ-M031G. No downflow. 3 NL/min (1 electrode) air purge

(8Hz)

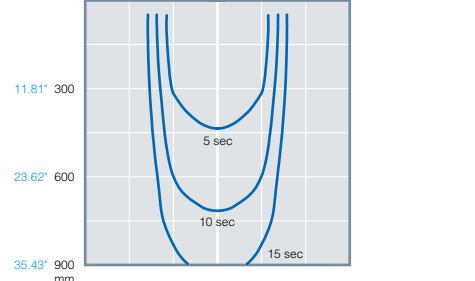

Measurement condition: Static elimination time from ±5,000 V to ±500 V. Using 150 mm × 150 mm 5.91" × 5.91" plate monitor (20 pF) Using SJ-M031G. Under a 0.3 m/s 0.98 ft/s downflow. 3 NL/min (1 electrode) air purge

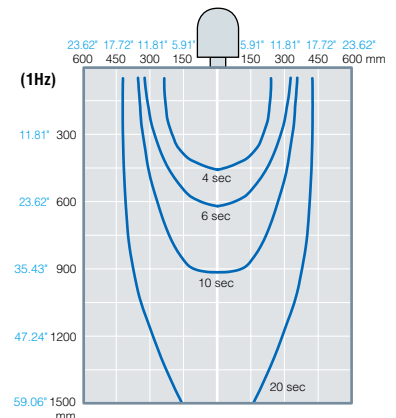

Measurement condition: Static elimination time from ±5,000 V to ±500 V. Using 150 mm × 150 mm 5.91" × 5.91" plate monitor (20 pF) Using SJ-M031G. Under a 0.3 m/s 0.98 ft/s downflow. 3 NL/min (1 electrode) air purge

Relationship between air pressure and air volume

SJ-M021G (By nozzle type)

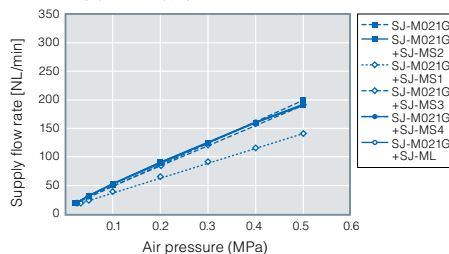

SJ-M021 (By nozzle type)

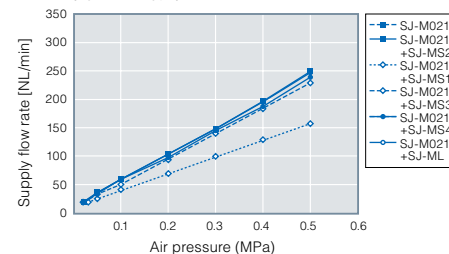

SJ-M031G

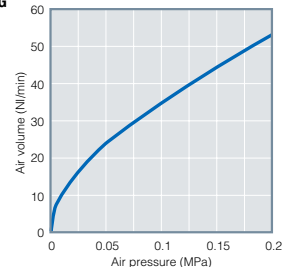

SJ-M021/M301

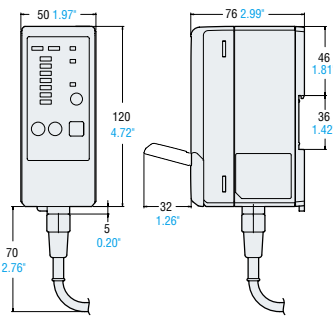

Drive unit for SJ-M021x/M031x/M071x

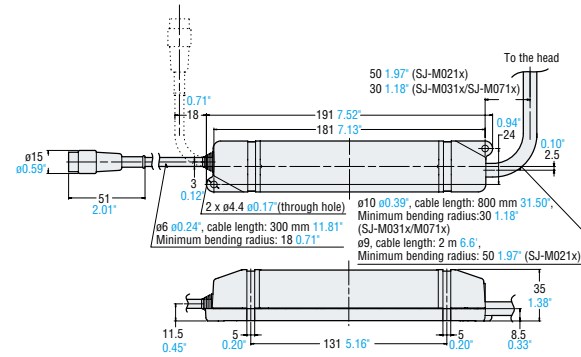

SJ-M021/M021G

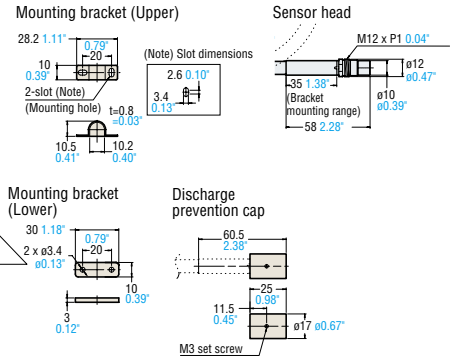

SJ-M031G/M031C

Front installation

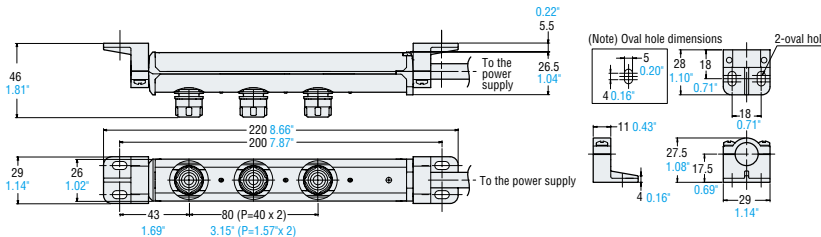

Side installation

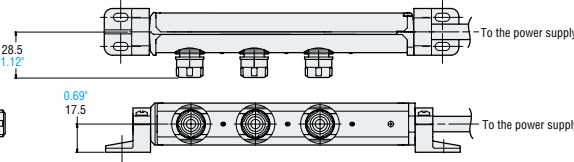

SJ-M071G/M071C

Front installation

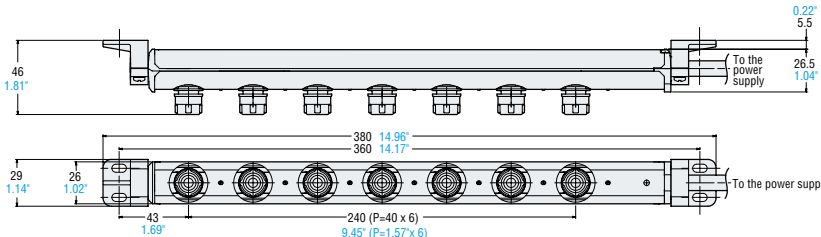

Side installation

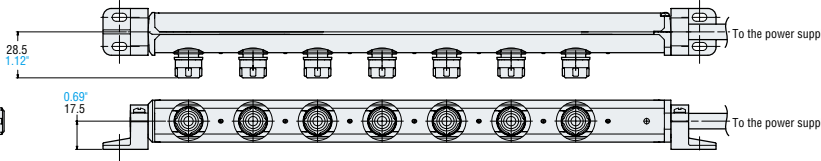

OPTIONS

Extension cable (3 m 9.84')



SJ-C3

(Between the controller unit and the high-voltage power supply)

AC adapter *



SJ-U3

* For details of the AC cable, contact the KEYENCE sales office in your district.

Discharge prevention cap **OP-75354**

Fluorine tube **OP-75350**

Electrode probe for SJ-M021G **OP-75351**

Electrode probe for SJ-M021 **OP-51607**

Electrode probe for SJ-M031G/M071C **OP-42214**

Electrode probe for SJ-M031G/M071G **OP-51644**



CALL TOLL FREE TO CONTACT YOUR LOCAL OFFICE
1-888-KEYENCE
1-888-539-3623

www.keyence.com

SAFETY INFORMATION
Please read the instruction manual carefully in order to safely operate any KEYENCE product.

CONTACT YOUR NEAREST OFFICE FOR RELEASE STATUS

KEYENCE CORPORATION OF AMERICA

Head Office 500 Park Boulevard, Suite 200, Itasca, IL 60143, U.S.A.

PHONE: +1-201-930-0100 FAX: +1-855-539-0123 E-mail: keyence@keyence.com

AL Birmingham	CA San Jose	CO Denver	IL Chicago	MI Detroit	MO St. Louis	NC Raleigh	PA Philadelphia	TN Nashville	WI Milwaukee
AR Little Rock	CA Cupertino	FL Tampa	IN Indianapolis	MI Grand Rapids	NJ Elmwood Park	OH Cincinnati	PA Pittsburgh	TX Austin	
AZ Phoenix	CA Los Angeles	GA Atlanta	KY Louisville	MN Minneapolis	NY Rochester	OH Cleveland	SC Greenville	TX Dallas	
CA San Francisco	CA Irvine	IA Iowa	MA Boston	MO Kansas City	NC Charlotte	OR Portland	TN Knoxville	WA Seattle	

KEYENCE CANADA INC.

Head Office PHONE: +1-905-366-7655 FAX: +1-905-366-1122 E-mail: keyencecanada@keyence.com

Montreal PHONE: +1-514-694-4740 FAX: +1-514-694-3206 Windsor PHONE: +1-905-366-7655 FAX: +1-905-366-1122

KEYENCE MEXICO S.A. DE C.V.

PHONE: +52-55-8850-0100 FAX: +52-81-8220-9097

E-mail: keyencemexico@keyence.com